

# NJROTC

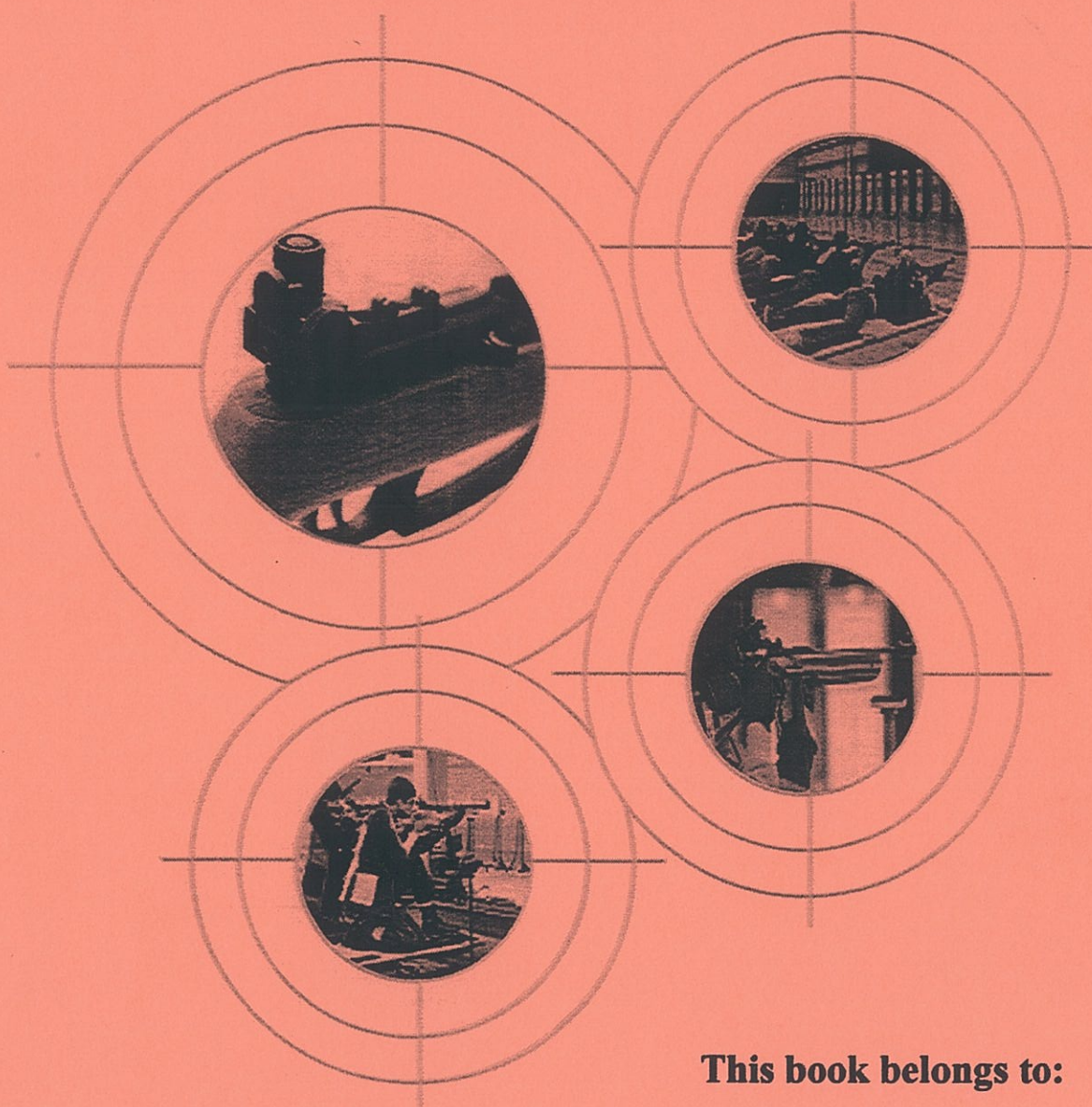

## JUNIOR POSITION AIR RIFLE HANDBOOK NAVEDTRA 37117



**This book belongs to:**

---

**Cadet's Name**



**NSN 0509LP1047153**

**April 2006**





# ***NJROTC Marksmanship Program***

## **Table of Contents**

<b><u>Lesson</u></b>	<b><u>Title</u></b>	<b><u>Page</u></b>
1	History of Marksmanship	1
2	Firearm safety and safe range operation	7
3	Target Shooting Equipment and its Operation	15
4	Aiming Basics and the First Target Position – Standing	23
5	Aiming and Firing	30
6	Sight Adjustment and Scoring	36
7	The Prone Position	43
8	The Kneeling Position	50
9	Practice and Skill Development	56
10	Competition Opportunities	65
Appendix A	Civilian Marksmanship Program Junior Shooter Safety Examination	
Appendix B	Safety Pledge	



## **Acknowledgements**

Mr. Gary Anderson  
Director, Civilian Marksmanship Program

Commander John W. Roberts, USN Retired  
NJROTC Senior Naval Science Instructor

Lieutenant Colonel Peter G. Peters, USMC Retired  
NJROTC Senior Naval Science Instructor

Lieutenant Ronald J. Maul, USN Retired  
NJROTC Senior Naval Science Instructor

The Navy Junior Reserve Officers Training Corps extends special thanks to these individuals for their efforts in development and editing of this publication and their dedication to marksmanship youth sports.



## LESSON 1: THE HISTORY OF MARKSMANSHIP

### PURPOSE

This lesson introduces you to the historic applications of marksmanship and its current application as a sport. It also identifies the qualities that make participants in the sport of air rifle target shooting safe and successful.



*accuracy  
concentration  
control  
determination  
practice  
skill*

### INTRODUCTION

From the time of the early settlers hunting to survive, to the citizen-soldier who first fought for our independence, to the modern military marksman who protects our freedoms, marksmanship has played a rich part of our country's history. Some would say that its only importance in this era is in military applications. What is overlooked is marksmanship as a sport and the tremendous personal benefits that can be achieved when training for and participating in competitive marksmanship matches.

Why participate in marksmanship competitions? Putting projectiles on target is something we all seem to enjoy from the moment we enter elementary school. How many of us shoot trash into the trashcan from across the room, or at least try to? All of our major sports have an aspect of marksmanship.



*From the time humans started throwing stones they have practiced their skills at using projectiles to hit targets. This sculpture of a primitive man throwing a stone is part of a statue on the Enrique Borbonnet Gomez shooting range near Havana, Cuba.*

### Marksmanship Sports in the Olympics

- **BIATHLON**, cross-country skiing and rifle shooting
- **PENTATHLON**, horse riding, fencing, swimming, running, and air pistol shooting
- **ARCHERY**, with bows and arrows
- **SHOOTING**, 17 events for rifles pistol and shotguns

Basketball, baseball and even football have skills of trying to put a projectile on target. Its fun! There is something satisfying when you sink the three-pointer, put that fastball just where the hitter can't hit it or put a round in the center of the ten-ring. We know from our experiences in competitions that none of these things are as easy as they sound and consistently putting a round in the ten-ring is very challenging.

In other sports your physical characteristics, i.e. height, weight and coordination, will go a long way in determining your maximum level of accomplishment. This is not the case in shooting competitions. The only limit to how good you can be is how hard you want to work. The great thing is all the benefits of other sports can be found in

marksmanship. Shooting requires self-discipline, self-control and above all dedication. And while you might think that stamina is not important to shooting, wait until your first couple practices and competitions. Those that can hold the rifle steady after several rounds of competition are going to be the winners.

The translation of marksmanship skills to your schoolwork and lifework is obvious. Not only will you develop self-discipline and confidence, but also when you shoot you will leave all your thoughts about school and day-to-day responsibilities behind. Your concentration will have to be complete. Can you do that now? Just imagine if you could sit down to take a test or do homework and completely concentrate on the subject matter! Learning marksmanship skills can help you do that.

When you participate in marksmanship you are not only learning a skill that helped found our great nation, but you are also participating in a highly competitive sport that will help you develop important life skills. Go out and have fun, enjoy the sport, understand and appreciate what it meant to the history of our country. Use the skills you learn and be a part of our future.

## A HISTORIC OVERVIEW

The evolution of target sports led to the development of four different sports that now are Olympic sports. The winter sport of biathlon combines cross-country skiing and rifle shooting. Modern pentathlon, archery, and shooting all are summer Olympic sports. Archery involves shooting with bows and arrows. Pentathlon combines air pistol shooting with horse riding, fencing, swimming, and running. The sport of shooting is one of the largest and most popular of all Olympic

sports with 17 different men's and women's events for rifles, pistols, and shotguns.

From ancient warriors to modern Olympic gold medallists, persons who demonstrated great skill in marksmanship tests were celebrated as heroes. Several ancient Egyptian Pharaohs were acclaimed for their archery skills through the inscriptions in their tombs. The legendary tales of medieval heroes such as William Tell of Switzerland and Robin Hood of England celebrated their ability to hit especially difficult targets with a crossbow or bow. The development of our country is highlighted by feats of marksmanship by the Minutemen of Concord and Lexington, frontiersmen such as Daniel Boone and military figures such as Berdan's Sharpshooters.

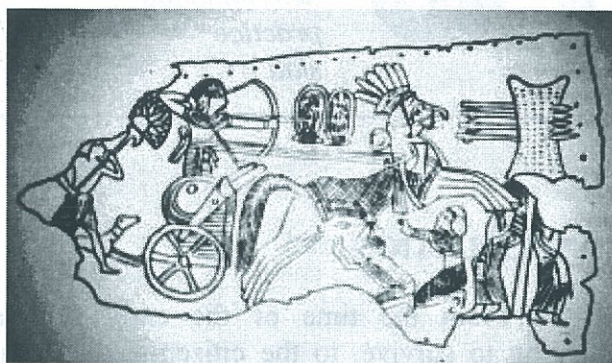

*The Egyptian Pharaoh, King Aye, was the successor to Tutankhamen, the famed King Tut. This drawing is copied from an inscribed gold leaf that shows the Pharaoh shooting his bow at a target that held by two prisoners while he rides by the target in his chariot.*

In the last 150 years, people who demonstrated exceptional skills while shooting at targets, from Annie Oakley to the gold medallists of the most recent Olympic Games, were raised to positions of honor. Target shooting is a sport that requires precise muscle **control**, intense **concentration**, mental and physical stamina, and unwavering emotional **control**. No matter when in human history great feats of marksmanship are performed, the



skilled marksman is respected, honored and celebrated.



*An advertising poster for Buffalo Bill Cody's Wild West Show of the late 1800s promotes the marksmanship skills of one of America's first great target shooters, Annie Oakley.*

## OLYMPIC COMPETITORS

Some of the greatest Olympic competitors are rifle shooters from the United States. Two of those shooters, Gary Anderson (1964, 1968) and Lones Wigger (1964, 1972) are among an elite group of Olympic medallists who have won two individual Olympic gold medals. Only one shooter in the history of the Olympic Games has won more than two individual gold medals (Ralf Schumann, a pistol shooter from Germany, won his third gold medal in 2004). One other U. S. rifle shooter, Morris Fisher (1920, 1924), who was a member of the Marine Corps, also won two individual Olympic gold medals.

Since 1948, six other U.S. rifle shooters have won Olympic gold medals. They are Arthur Cook (1948), John Writer (1972), Lanny Bassham (1976), Edward Etzel (1984), Pat Spurgin (1984), Launi Meili (1992), Nancy Napolski-Johnson (2000) and Matt Emmons (2004). Another important milestone in the

history of marksmanship occurred in 1976 when Margaret Thompson-Murdock of the U.S. won a silver medal to become the first woman to ever win an Olympic medal in shooting.



*U. S. Army rifle shooter Lones Wigger is one of the all-time greats. He won two Olympic gold medals, two World Championships and dozens of other international medals.*

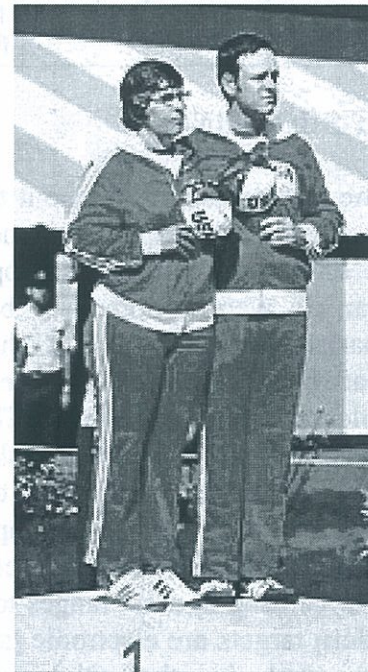

*Margaret Murdock-Thompson, USA, stands on the victory podium at the 1976 Olympics with gold medallist Lanny Bassham, USA. Her silver medal made her the first woman ever to win an Olympic medal in shooting.*

The current Olympic program includes five different rifle events, two for women and three for men. The chart (below) provides

additional information about these Olympic target-shooting events.

Event	Type of Gun	Distance	Shooting Position	No. of Shots
Air Rifle Women	Air rifle	10 meters	Standing	40 shots, plus 10 shots in final
Air Rifle Men	Air rifle	10 meters	Standing	60 shots, plus 10 shots in final
Three Position Rifle Women	.22 caliber rim fire	50 meters	Prone, standing and kneeling	60 shots (20 in each position) plus 10 shots in final
Three Position Rifle Men	.22 caliber rim fire	50 meters	Prone, standing and kneeling	120 shots (40 in each position) plus 10 shots in final
Prone Rifle Men	.22 caliber rim fire	50 meters	Prone	60 shots, plus 10 shots in final

## TARGET SHOOTING

The targets used throughout the history of marksmanship are graphic evidence of how the sport of target shooting developed. The earliest targets were cylinders or boxes with central marks that were used by archers. Live, and later artificial, pigeons were once placed on top of poles and used as targets. The earliest rifle targets were large wooden disks. Large steel plates were used for early rifle targets and gave audible signals when hit. Paper targets came into use in the late nineteenth century and continue to be used in most ranges today. The most modern targets are electronic targets such as those used in the Olympic Games. Electronic targets have acoustical sensing systems that pinpoint and score the exact location of each shot and computer systems to calculate the scores and display instant results on electronic scoreboards.

The targets used today have concentric scoring rings. Shots that touch the central or

inner ring score ten points. Shots that hit the next ring score nine points. Successively poorer shots score values down to one or even zero.

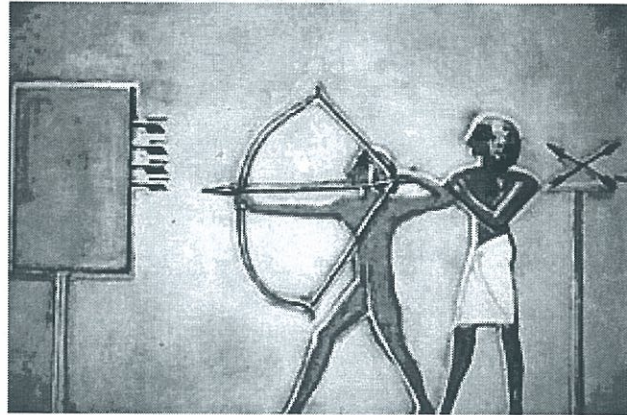

*Targets used in Ancient Egypt 4,000 years ago were simple boxes or cylinders.*



*Rifle targets in seventeenth and eighteenth century Europe were large wooden disks that were fired at from distances of as much as 400 meters. The young boy was called a "Scheibentoni" or target marker.*

All target shooting events trace their origins to survival or martial skills that originally were intended to prepare men for battle. Target sports have a strong military

heritage and target training is sometimes **practiced** as part of modern military or police training. Today, however, target rifle shooting is primarily **practiced** as a sport in the same way that basketball, swimming, running and skiing are sports. All sports have special qualities that make them unique. Target shooting participants need to know about some of its special qualities.

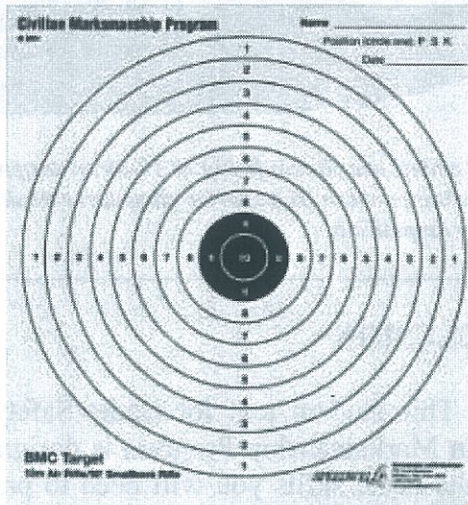

*The most common targets today are paper targets with scoring rings that have values from one to ten. Shots hitting the center ring score ten points; shots hitting the next ring score nine points, etc.*

*Target shooting is a sport that can be practiced by everyone.* Successful target shooters are tall and short, stocky or thin. They must have reasonable flexibility and coordination, but no other special physical attributes are required. Shooters need to be able to see well, but it does not matter if their good vision is achieved by wearing eyeglasses or contact lenses. Indeed, the most important prerequisite for successful target shooting is an interest in the sport and a motivation to practice and learn. Success in shooting is **determined** by how hard one works, not by how much ability someone has.

*Target shooting is a sport where women and men compete equally.* In shooting neither sex has an advantage. In high school and

college rifle competitions where men and women compete together, men and women win awards in direct proportion to their numbers.

*Target shooting is a skill sport.* All sports test different combinations of speed, strength, endurance and skill. Running is a test of speed or endurance. Weightlifting is a test of strength and skill. Figure skating is a test of strength and skill. Target sports are tests of skill. The special thing about skill sports is that no one is born with those skills, they are developed through training.

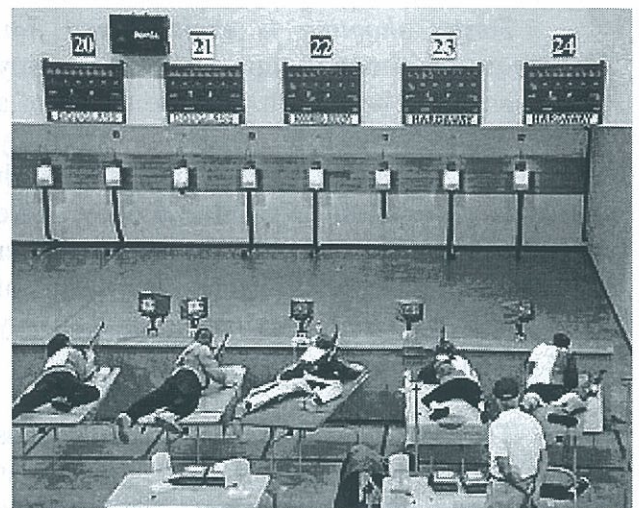

*Electronic targets with acoustical-sensing systems that locate and score each shot are the most modern target system.* With electronic targets, the shooter shoots into a target box that records the shot, displays its location and score on a monitor in front of the shooter and displays the score for spectators on a scoreboard above each shooter. The shooters in this photo are competing in the Georgia High School Rifle Championship on the range that was built to host the 1996 Olympic Games in Atlanta.

*Target shooting is a sport of control, discipline and concentration.* It is not possible to handle guns safely or to advance in target shooting without having a great deal of self-discipline and **control**. It is not possible to fire consistent, accurate shots without developing great **concentration** skills. Target shooting

does an exceptionally good job of teaching these and many other vital life skills.

*Target shooting enjoys worldwide popularity.* In the most recent Olympic Games, shooting ranked number three in the number of nations that qualified participating athletes. Only athletics (track and field) and swimming had more. Over 140 nations have organized target-shooting programs and belong to the International Shooting Sports Federation. Target shooting has more than 150 million participants throughout the world and is one of the most popular participation sports.

*Target shooting is exciting and fun.* The sport of shooting appeals to so many people precisely because hitting the center of a target on a consistent basis is extremely challenging. Trying to hit the center of difficult targets is a great test of mind and body. The thrill of firing a great shot that strikes the center of a target is as exciting as the thrill of successfully performing a difficult skill in any sport.

The type of rifle marksmanship that is taught and **practiced** in the JROTC program is three-position air rifle shooting that is done with 4.5 mm (.177 cal.) air rifles with the targets placed at a distance of 10 meters. JROTC riflery was once done with .22 cal. rim fire rifles with the targets placed at a distance of 50 feet. Three-position air rifle target shooting that is done by JROTC cadets is

closely related to the air rifle standing and three-position smallbore rifle events that are in the program of the Summer Olympic Games.



*JROTC cadets are shown firing at 10-meter targets in the standing position in a sporter class three-position air rifle competition.*

## CONCLUSION

This student text for Cadet Safety and Civilian Marksmanship Program is designed to teach the basic skills you will need to practice the sport of target rifle shooting. The objectives of this marksmanship training program are to teach you how to handle guns safely, how to perform the basic skills of the sport of target shooting, and to give you the fundamental knowledge necessary to begin competing in three-position rifle competitions as a member of a JROTC or high school rifle team.

## LESSON 2: FIREARM SAFETY AND SAFE RANGE OPERATION

### PURPOSE

This lesson introduces you to the rules for safe air rifle handling and the range procedures that you must follow in air rifle firing activities.



*action*  
*muzzle*  
*safety*  
*trigger*  
*CBI*

### INTRODUCTION

The sport of target rifle shooting is one of the safest of all youth sports. In 104 years of Olympic shooting, there has never been an accidental injury involving a firearm. There are several thousand JROTC teams and junior rifle clubs that practice and compete in position air rifle shooting, with more than 100,000 participants in the USA. These youth marksmanship activities have established one of the lowest accident rates of any youth sport.

Target shooting established its record as one of the safest of all sports because it is a sport where the safety of its participants can be assured when everyone follows basic safety rules. Target shooting is, in fact, a sport of control and discipline where everyone involved, including participants, instructors, coaches, and range officers, are expected to know and apply the sport's safety rules at all times.

### RULES FOR SAFE GUN HANDLING

There are three basic rules that are the foundation for the safe handling and shooting of all types of guns. These rules fully apply to the air rifles that are used in JROTC marksmanship programs. These fundamental safety rules focus on three key parts of every gun that control when and where the gun can be fired. Those parts are the **MUZZLE**, **ACTION**, and **TRIGGER**.

Everyone should know these basic parts of a gun, whether or not they ever will be involved in target shooting, so that they can practice the rules for safe gun handling any time they are in a situation where a gun is present.

- **MUZZLE.** The forward end of the barrel. The point where the pellet or projectile leaves the barrel when the gun is fired. A gun is aimed by pointing its **muzzle** at the target.
- **ACTION.** The working mechanism of the gun. Gun **actions** typically have a bolt or lever that is used to open and close the action so that the gun can be loaded and unloaded.
- **TRIGGER.** The **trigger** is part of the action or working mechanism of the gun. The trigger is a lever that projects out of the bottom of the gun. A trigger guard protects the trigger. After a gun is loaded and the action is closed, the gun is fired by pulling the trigger.

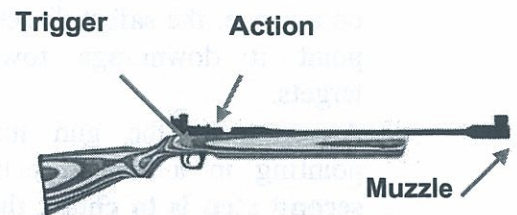

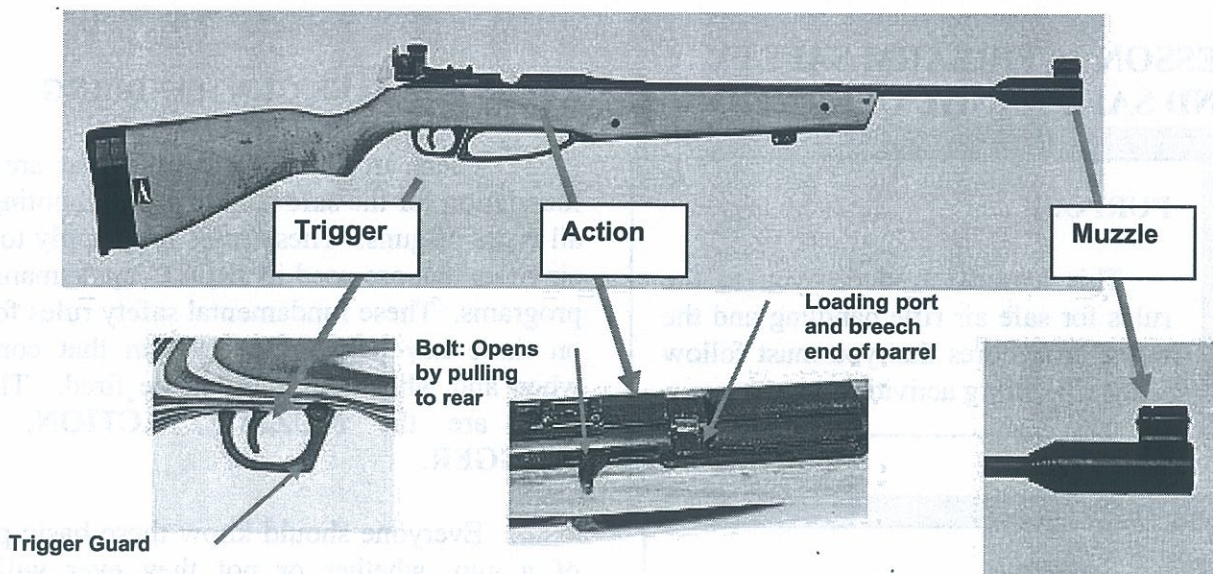

### THREE SAFETY STEPS

The application of the rules for safe gun handling follow a step-by-step sequence that is designed to assure that even if a gun were to be unintentionally fired, it would not cause personal injury or serious damage. Be sure to follow these steps:

- Whenever anyone picks up a gun of any kind, **the first thing that must be done is to control the direction the muzzle points.** Immediately point the gun in a safe direction where it is not directed at another person and would do no serious damage even if the gun were to be unintentionally fired. The first thing to do when picking up a gun or taking a gun from someone else is to point it away from other people in the area. The safest direction to point a gun is usually up. If a gun is on a range, the safest direction is to point it downrange toward the targets.
- As soon as the gun muzzle is pointing in a safe direction, **the second step is to check the action of the gun and to open it if it is not**

**already open.** Since the gun's action contains its firing mechanism, it cannot be fired unintentionally or accidentally if the action is open. All guns, except muzzle loading guns, have a bolt or lever on the action that is used to open the action. Be sure to learn where the bolt or cocking lever is on any gun you handle. With the action open, it is possible to visually check most guns to see whether the gun is loaded and has a cartridge or pellet in the breech end (rear end) of the barrel. If the gun is loaded and it is possible to remove the cartridge, that must be done.

- With the muzzle pointing in a safe direction and the action open so that the gun cannot be fired, **the third safety precaution is to hold or carry the rifle so that all fingers are held outside of the trigger guard and not on the trigger itself.** The trigger guard is a protective loop around the trigger. Its purpose is to protect the trigger from being pulled unintentionally. By keeping fingers outside of the trigger guard, it is impossible to accidentally pull the

trigger should the action somehow become closed.

### CLEAR BARREL INDICATORS (CBIs)

Clear Barrel Indicators or CBIs are used to demonstrate that air rifles are not loaded with a pellet and that their actions are open. CBIs are made from bright-colored monofilament line. CBIs are inserted in air rifle barrels from the breech (action) end of the barrel and extend out both ends of the barrel.



### RULES FOR SAFE GUN HANDLING

1. **MUZZLE.** Always keep gun muzzles pointed in a safe direction. Gun muzzles should never be pointed at other persons under any circumstances. On a range, the safest directions to point a gun muzzle are usually upward or downrange toward the target.
2. **RIFLE ACTION.** When handling any rifle or firearm, the action should be open. Gun actions must remain open except when the gun is on the firing line and the command to LOAD has been given. When shooting is finished or the rifle is placed down to take a break, the action must be open and unloaded, even when the gun is on the firing line. The gun action may be closed and the CBI moved forward when it is placed in a gun case or storeroom, but must be opened and the CBI inserted as soon as it is picked up again.
3. **TRIGGER.** Keep your finger off the trigger until after placing the gun in the shooting position and preparing to fire a shot. It is especially important to keep the finger outside of the trigger guard when loading the gun and placing it in the shooting position.

### SHOOTING RANGES

Everyone who comes in contact with a gun needs to know the three basic rules for safe gun handling. Individuals who will use rifles in JROTC marksmanship or other target shooting activities also need to know and practice several additional rules regarding the safe operation of target shooting ranges.

To understand these safety rules it is first necessary to know something about how target ranges are designed. Study the diagram of the range (next page) so that you understand how the firing points and targets are positioned on a typical range. This diagram is for a six-point range, but target ranges can have as few as four and as many as 100 or more firing points.

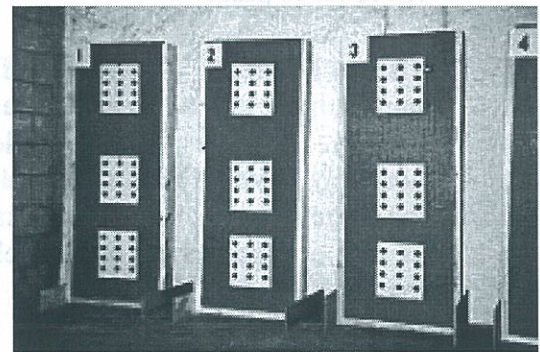

*10-meter air rifle range target holders with targets placed at the proper heights for firing from the prone, kneeling, and standing positions.*

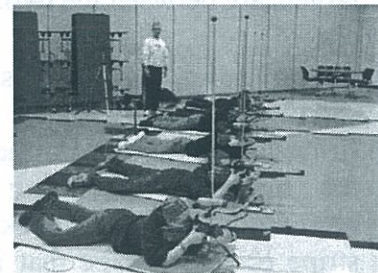

*A range officer or instructor is in charge of firing on every range.*

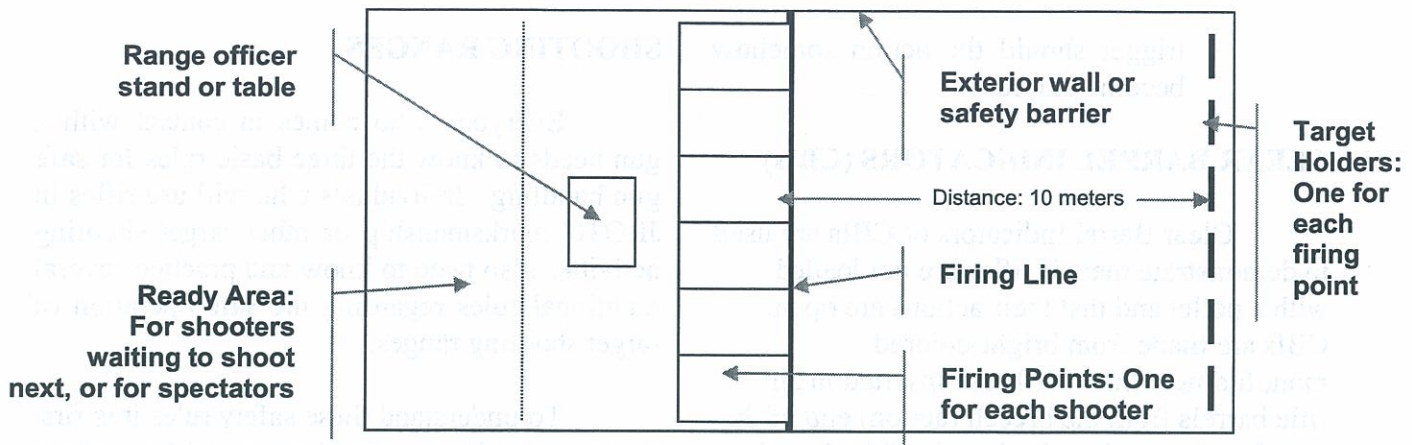

Each range has these primary features:

- Safety Barrier.** Ranges normally have an outside wall or some means of preventing unauthorized persons from entering the range area while firing takes place.
- Target Holders.** At one end of the range there are a series of target holders. The target holders normally have a metal sheet behind the targets that serves as a backstop to stop and collect all of the pellets that are fired at the targets. The target holders are designed so that targets can be hung on them at heights appropriate for the three shooting positions. Prone targets are hung low, standing targets are placed chest high, and kneeling targets are between the two.
- Firing Line.** At a distance of exactly 10 meters from the targets, a firing line is marked on the floor of the range. The firing line is normally a red or black painted stripe or line of tape that is two or three inches wide. All shooters must position themselves on their firing points so that no part of their feet or body touches the firing line.
- Firing Points.** The firing line is broken into divisions called firing points. Firing points are rectangular spaces behind the firing line. Firing points are approximately 1 meter x 2 meters in size. The width of each firing point corresponds to the distance between the targets. Only one shooter may occupy one firing at one time.
- Range Officer.** Immediately behind the line of firing points, a table or stand for the range officer is located. The range officer is in charge of firing on the range and gives instructions to control shooting. Range officers use a standard series of range commands that control the conduct of any shooting activity.
- Ready Area.** Most ranges also have an area behind the firing line that is designated as a preparation or ready area. If there are spectators, this is the area where they should stand or sit. If there are other shooters who are waiting their turn to fire, this is the area where they should remain.

## FIRING PROCEDURES AND COMMANDS



The range officer or instructor conducts the firing activity on the range. To begin a range activity, the range officer designates the shooters who will use the firing points and instructs them to move their equipment to the firing line. When air rifles are brought to the range, their muzzles must be pointed upward or downrange, their **actions** must be open and they must have CBIs inserted in the barrels. After bringing air rifles to the firing line, they must be “grounded.” This means to place them on the floor, shooting mat or bench with the muzzle lying ahead of the firing line. The range officer will then give instructions to prepare for firing. After the shooters are in shooting positions ready to fire, the range officer gives a series of commands to start and stop firing.

- **LOAD.** No one may load any rifle until the range officer gives the command **LOAD**. Then shooters may charge their rifles with air and insert a pellet. It is a serious offense to load a rifle on a range before the command **LOAD** is given.
- **START.** The next command tells shooters they can begin to aim and fire at their targets. No one may fire a shot until this command is given, even if the command **LOAD** has been given. After the command **START** is given, shooters may continue to charge and load their rifles to fire all of the shots in a firing exercise.
- **STOP.** When shooting is finished, the range officer commands **STOP**. If the command **STOP** is given during firing, every shooter must immediately stop firing, open the **actions** on their rifles and wait for further instructions. No one is

authorized to fire a shot after the command **STOP** is given. The range officer or any other person on the range can command **STOP** if they become aware of a dangerous or unsafe condition.

- **UNLOAD.** If anyone on a range has a loaded air rifle after the command **STOP** is given, they must notify the range officer by raising their hand or calling out “*Loaded rifle.*” The instructor will then give directions for unloading any loaded rifles. Loaded air rifles are normally unloaded by firing the rifle into an Pellet Discharge Container (PDC).

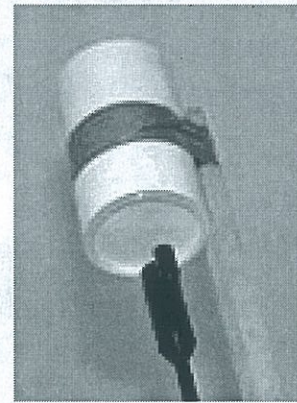

*A Pellet Discharge Container (PDC) is filled with paper or other material. When an air rifle remains loaded after the command STOP is given, the range officer will instruct that the rifle be unloaded by firing it into the PDC.*

As soon as you complete a firing exercise, you must 1) immediately open your air rifle action, 2) ground your rifle and 3) insert a CBI in the barrel.

After all firing is completed the range officer will check each rifle to be sure they are unloaded with CBIs inserted. When that check is completed, the range officer will instruct the shooters on the firing line to retrieve or change

their targets or to leave the firing line so the next group of shooters can move up to the firing line.

There are a few other rules that are used on shooting ranges to assure safety and the orderly conduct of shooting activities. Every shooter must be familiar with these rules and any special rules that apply to the range you are using.

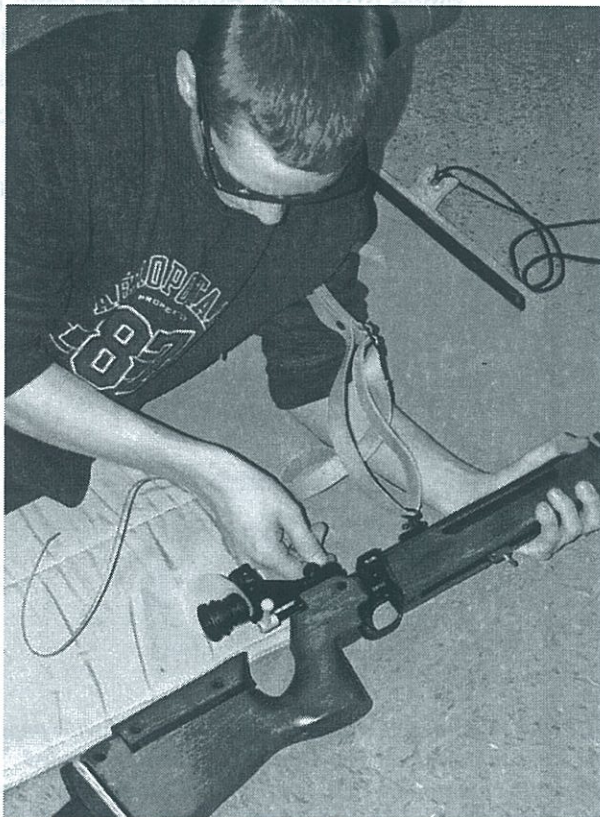

*A JROTC cadet inserting a CBI into the barrel of a grounded air rifle after completing a firing exercise.*

**EVERYONE IS A RANGE SAFETY OFFICER.**

Everyone who participates in target shooting is not only responsible for safely handling the guns that they use, but also for making sure other people around them handle guns safely too. If you see someone point an air rifle muzzle at another person or handle a gun with the action closed, correct them immediately. A safe shooter is someone who not only handles guns safely themselves, but who also does not tolerate unsafe gun handling by others around them.

**ADDITIONAL RANGE SAFETY RULES**

**SAFETY IS NOT AN ACCIDENT.** It takes a concerted effort by all involved to insure your shooting environment is a safe one. Gun safety requires that you consciously practice safe muzzle control, check for open actions and keep your fingers outside the trigger guard every time you handle a gun. Safety requires self-discipline and focus. Always pay attention to safety. Not just for yourself but for all your shipmates around you.

1. **PROPER AIR RIFLES FOR THE RANGE.** Only 4.5mm air rifles designated for target air rifle shooting (described in lesson 3) can safely be used on JROTC air rifle ranges.
2. **TARGET.** Shoot only at the target designated for you. Be sure your target is properly placed in front of a safe backstop. Shooting at any object on a range besides your own target is strictly forbidden.
3. **LOADING.** Rifle muzzles must remain pointed downrange or upward whenever the rifle is charged with air and loaded. Special care must be taken to assure that a rifle muzzle is never allowed to point at a neighboring shooter or to any area behind the firing line during charging and loading.
4. **MALFUNCTIONS.** If at any time during a firing exercise, your air rifle fails to fire properly, keep the muzzle pointed downrange and raise your hand so the Range Officer can see it. Be patient and wait for instructions from the Range Officer. If the rifle is loaded, the Range Officer must remove the pellet before the rifle is removed from the firing line.
5. **FIRING COMPLETED.** Immediately after you fire your last shot in a firing exercise or when the command STOP is

given, you must open the action on your air rifle, place the rifle on the ground or bench and insert a CBI. The Range Officer will then inspect the firing line to insure safety.

6. **LOADED RIFLE.** A loaded air rifle is an air rifle that has a pellet in the barrel. Any pellet that is in the barrel must be removed before the air rifle may be grounded or removed from the range. If you still have a loaded air rifle after the command STOP is given, keep the muzzle pointed downrange, raise your hand and announce, "**Loaded rifle.**" The Range Officer will give you instructions for discharging your air rifle to unload it. This may be done by instructing you to fire into an open target backstop or to fire into a pellet discharge container.
7. **GROUNDING RIFLE.** When you bring your rifle to the firing line, you will be instructed to "ground" it. You must also ground your rifle after you finish firing to insert a CBI so it can be checked by the Range Officer. To ground a rifle, open the action, place it on the ground or bench with the muzzle ahead of the firing line and insert a CBI.
8. **LINE IS HOT/LINE IS CLEAR.** When conducting firing, the Range Officer will alternately describe the firing line as being "hot" or "clear." A firing line is hot when all persons on the range are in proper locations behind the firing line and the line is prepared for live firing. Further instructions or command will then be given to actually begin preparation and firing. A firing line is clear when all firing is completed and all rifles are grounded with CBI's inserted. No one can move forward of the firing line until it is declared clear by the Range Officer.
9. **GOING DOWNRANGE.** Whenever it is necessary for someone to go forward of the firing line to place or retrieve a target or for any other purpose, all air rifles must be grounded with CBIs inserted. No one may go forward of the firing line until authorized to do so by the range officer and no one may handle rifles while anyone is in front of the firing line.
10. **PERSONAL HYGIENE.** Lead is a toxic substance that must not be ingested. Medical research conducted at the U.S. Olympic Training Center confirms that simple hygiene precautions effectively prevent individuals who shoot air rifles from ingesting any lead. The rules are simple: 1) *Do not bring any food into the range or consume any food on the range;* 2) *Do not bring any drinks into the range unless they are bottled and can be closed;* 3) *Wash your hands in cold water after handling air rifle pellets. The instructor or another adult must clean the target backstops of spent lead pellets.*
11. **EYE AND HEARING PROTECTION.** Wearing eye protection is recommended for air rifle shooting because of the remote possibility that a piece of a lead pellet could bounce back off of the backstop. Some shooters also wear hearing protection (ear plugs) while shooting air rifles even though noise levels are at or above harmful levels. They do this mostly when they wish to reduce noise and improve their ability to concentrate.
12. **GUN CASES.** Air rifles are often brought to the ranges in gun cases that can be locked for security and are used to transport the rifles. When an air rifle is taken from its case, the first thing that must be done when the case is opened is to open the bolt of the rifle and insert a CBI. When the Range Officer gives instruction to take the air rifles and equipment to the firing line, take your gun case with the rifle in it to the firing point

with the case oriented so the muzzle points downrange. As soon as you open the case, you must open the action and insert a CBI in the rifle. You can then take the rifle from the case to ground it on your firing point and remove the gun case from the firing line. When firing is completed the Range Officer will give instructions to replace it in the case. After the gun is in the case you can close the action, remove the CBI, release the trigger and close the case.

**13. AIR RIFLE STORAGE.** After a shooting session is completed the air rifles must be stored in secure, locked storage. When firing is completed, you may be instructed to bring the rifles to a storage area where your instructor will be in charge of accounting for and locking up the rifle. Whenever you carry your rifle from the range to the storage area, be sure to keep the muzzle pointed upward and in a safe direction.

**14. AIR OR CO2 CYLINDERS.** Some air rifles used in JROTC marksmanship activities utilize air or CO2 cylinders as a means of propulsion. These cylinders are safe if handled properly but proper safety precautions must be taken. When screwing filled cylinders into air rifles, do not over-tighten the cylinders. When filling cylinders from a master tank, always stand to the side of the cylinder; do not allow its end or base to point at you or another person. Tighten the cylinder only enough to prevent gas leakage; never over-tighten it. High-pressure air or gas cylinders come with factory recommendations for periodic inspections; these must be followed.

## **BECOMING MARKSMANSHIP QUALIFIED**

There are three steps for a cadet to become marksmanship qualified:

1. **Safety training class.** A cadet must complete the safety training class from their instructor. Instructors giving the safety class must be a graduate of the JROTC Marksmanship Instructor Training Course (JMIC).
2. **Safety examination.** Cadets must complete the Civilian Marksmanship Program Junior Shooter Safety Examination with a score of 100%. A copy of this exam can be found in Appendix A of this manual.
3. **Shooter pledge.** Cadets must read and sign a copy of the Cadets Safety Pledge a copy of which can be found in Appendix B of this manual.

## **CONCLUSION**

The most important lesson that cadets who participate in marksmanship learn is how to be safe while handling any type of air rifle or firearm. By learning and following the rules of safe gun handling and the range safety rules for your range and by practicing those rules during target rifle practice, anyone who participates in marksmanship will acquire the knowledge and skills to handle all guns safely. This knowledge will not only assure safety during JROTC marksmanship activities, but it will insure that *any* encounter a person has with a firearm is a safe encounter.

## LESSON 3: TARGET SHOOTING EQUIPMENT AND ITS OPERATION

### PURPOSE

This lesson introduces you to the parts and components of the air rifle, how it functions and how to load and fire it. It also gives you details about the proper clothing and equipment needed for air rifle target shooting.



*action  
cocking lever  
front sight inserts  
kneeling roll  
loading port  
pistol grip  
rear sight blinder  
sling swivel*

### INTRODUCTION

Before you can target shoot on a range, you must know how to handle guns safely. It is also important to know about the purpose and functioning of the air rifles and equipment that you will use. This chapter introduces you to the air rifles and equipment used in JROTC marksmanship training and the basic principles of their operation.

The most common air rifle that is used in JROTC marksmanship training is the Daisy M853 pneumatic air rifle. Some JROTC units have Daisy M753 air rifles that are the same as the M853, except that they have an improved stock design and better sights. Some JROTC units now are acquiring newer Daisy M888, Daisy XS40 or Crosman M2000 CO<sub>2</sub> air rifles. Some units also have various types of precision air rifles. Most of those units, however, reserve these precision air rifles for members of their rifle team.

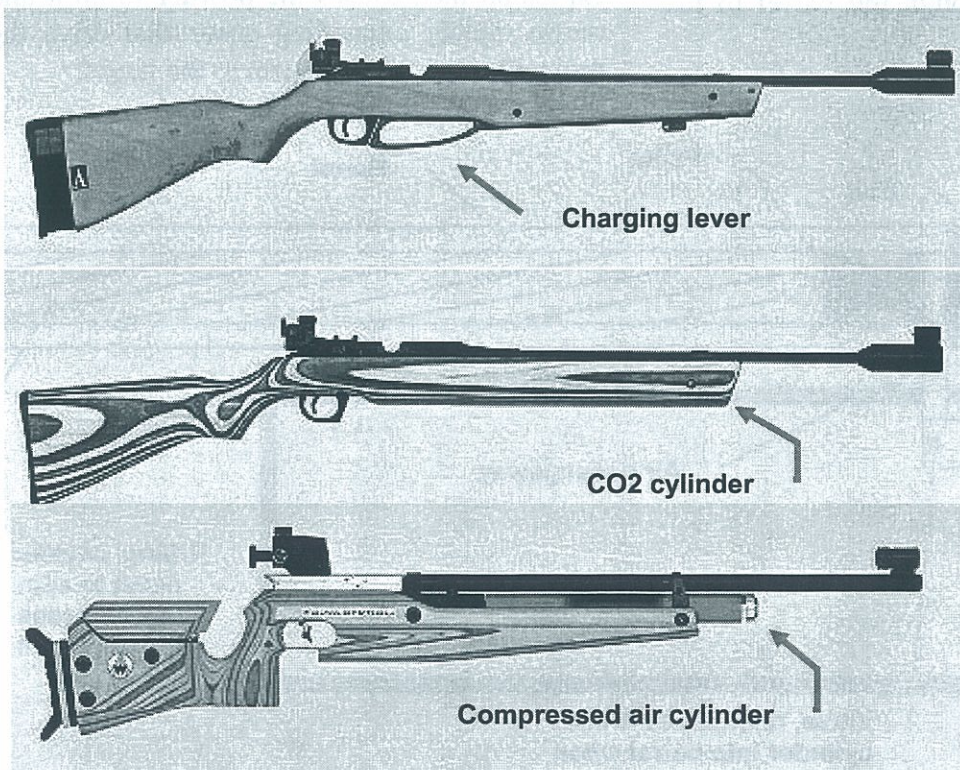

*The Daisy M853 air rifle is a pneumatic air rifle. The cocking lever is opened and closed to compress air in a chamber. The compressed air is released by a valve when the shot is fired.*

*The Daisy M888 air rifle uses compressed carbon dioxide (CO<sub>2</sub>) gas contained in a cylinder in the fore end of the stock to provide energy to fire the air rifle pellet.*

*The Feinwerkbau P70 Junior is a typical precision class air rifle that uses compressed air contained in a cylinder in the fore end of the stock to provide energy to fire the pellet.*

The projectiles used in air rifles are called pellets. They are made of soft lead, are 4.5mm in diameter (.177 cal.) weigh about eight grains (0.50-0.53 grams) and possess about five foot pounds of energy when fired. Air rifle pellets are shaped like badminton shuttlecocks. They have flat, solid heads and hollow skirts that help to stabilize them when they fly to the target. Air rifle pellets must be loaded so that the head is pointed at the target and the skirt is directed to the rear.

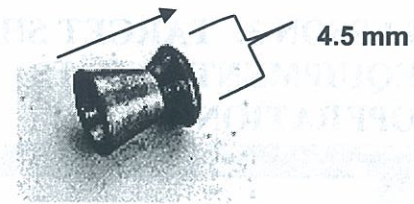

*Air Rifle Pellets*

**HOW AIR GUNS WORK**

To fire their projectiles, air rifles utilize energy that is stored in the form of compressed gas. If the air rifle has a pneumatic system, energy is stored when the rifle is cocked. If the air rifle has a CO<sub>2</sub> or compressed air system, a pre-charged cylinder that contains stored energy in the form of compressed air or CO<sub>2</sub> gas is attached to the rifle. Air rifles are fired when the trigger mechanism is activated to open a valve that releases compressed gas into the barrel. This gas expands rapidly into the rear or breech end of the rifle's barrel and drives the projectile through the barrel to the target.

In contrast with air rifles, firearms utilize energy that is stored in the form of gunpowder that is contained in a cartridge. The cartridge also contains a bullet (projectile) and a primer. The cartridge is placed in a chamber at the breech end of the barrel. The cartridge is locked in place by closing the action or bolt. Firearms are fired when the trigger mechanism is activated to release a firing pin that strikes and detonates the primer. The primer explosion then causes the powder to burn and create rapidly expanding gases that drive the projectile through the barrel to the target.

**AIR RIFLE SYSTEM**

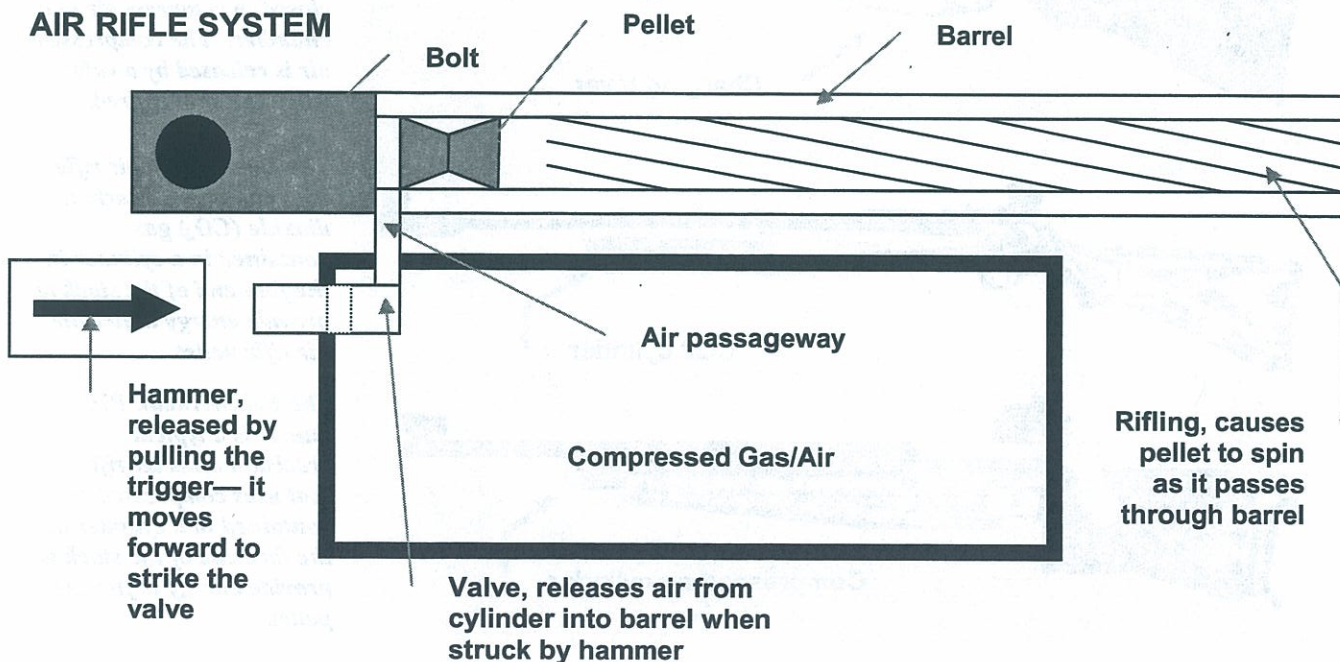

## WHAT MAKES RIFLES ACCURATE

When a rifle is fired at a target, two special features that are characteristic of rifles make it possible for the person who fires the rifle to direct the projectile at a precise point on the target. Those features are sights and rifling.

1. **Sights.** All rifles have sights. Target rifles have very precise, adjustable sights. Sights serve as a guidance system for the rifle that is controlled by the person who fires the rifle. The person who holds and fires the rifle looks through the rear and front sights to aim the rifle at the target. To hit the center of the target, the sights must be adjusted so that they point at exactly the same location on the target as the barrel points.

2. **Rifling.** All rifles also have rifling. Rifling is a pattern of flat spiral ridges inside the barrel that cause the pellet or projectile to spin when it leaves the barrel and flies through the air to the target. When a round or cylindrical object travels through air, it becomes unstable. To make that object stable and fly straight, it is necessary to make it spin. A Frisbee flies straight if it is spinning, but when it is not spinning fast enough, it wobbles and flies in unpredictable directions. The same is true of the air rifle pellet.

## PARTS OF AN AIR RIFLE

During rifle marksmanship instruction, frequent reference will be made to the different parts of the rifle. In addition to the rifle's basic parts, the muzzle, action, and trigger, it is important to know several other parts of the target air rifle. Learn to identify each of the parts identified on the chart below.

## PARTS OF A TARGET AIR RIFLE

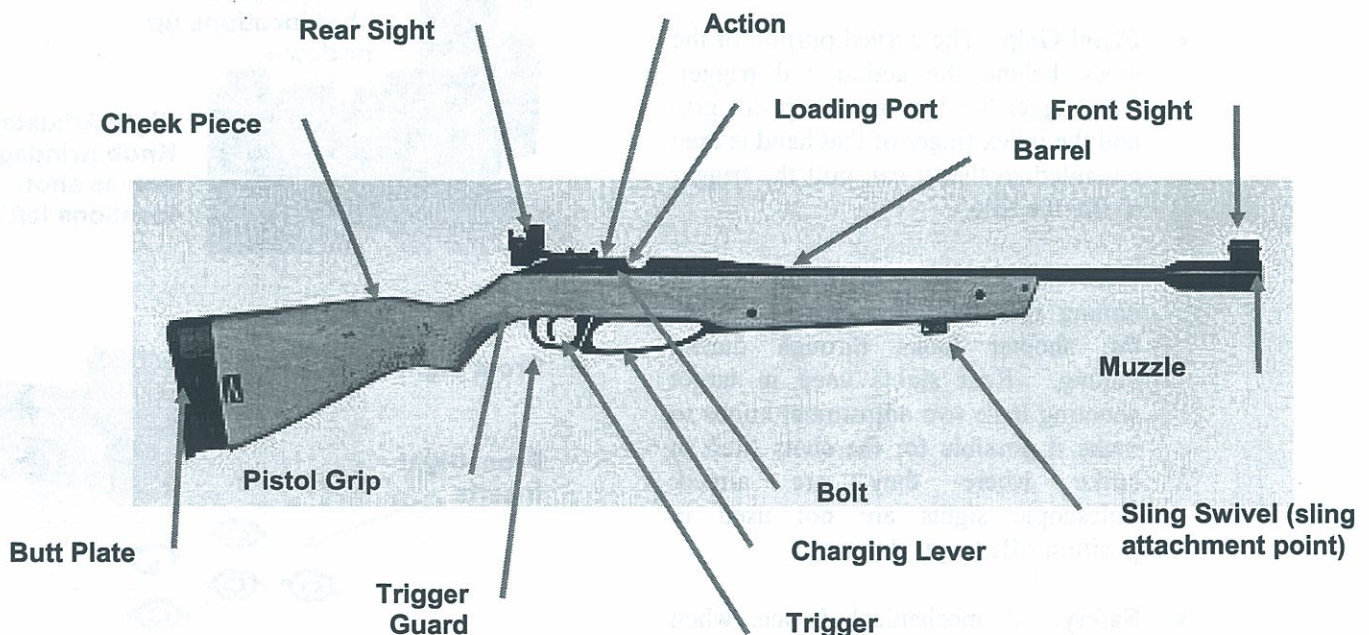

- **Bolt.** A handle or lever that is used to open and close the action of the rifle.
- **Loading Port.** The location where the pellet is loaded into the barrel. When the action is opened, the loading port is open so that a pellet may be placed in the breech end of the barrel.
- **Barrel.** A rifled tube that controls and directs the projectile when it is fired.
- **Cheek Piece.** The top part of the butt stock on which the shooter rests his/her cheek while looking through the sights to aim.
- **Charging Lever.** On the Daisy M853, the cocking lever is opened and then closed so that a piston can compress air into the air cylinder. Compressed air or CO<sub>2</sub> air rifles do not have cocking levers.
- **Trigger Guard.** The trigger guard protects the trigger from catching on clothing or another object. This helps to prevent the trigger from being accidentally pulled.
- **Pistol Grip.** The curved portion of the stock behind the action and trigger. The trigger hand grasps the pistol grip and the index finger of that hand is then extended so that it can pull the trigger to fire the rifle.
- **Rear Sight.** The rear sight has an aiming aperture with a small hole that the shooter looks through during aiming. Rear sights used in target shooting have two adjustment knobs to make it possible for the shots fired to strike where they are aimed. Telescopic sights are not used in position rifle target shooting.
- **Safety.** A mechanical device, when engaged, prevents trigger movement and therefore the firing of the rifle.

- **Front Sight.** The front sight has a ring or post insert that is used in aiming. The front sight inserts come in different sizes and can be changed so that the correct size front sight aperture is used.
- **Butt Plate.** The plate that covers the rear end of the stock. It is placed on the shooter's shoulder when holding the rifle in a shooting position to fire at a target. The butt plates on most air rifles used by JROTC units have spacers that can be removed or added to adjust the length of the stock. It is very important that each shooter use a stock that is the correct length.
- **Sling Attachment.** Target rifles have a sling swivel or sling attachment point, where the sling that is permitted in prone and kneeling positions is attached. The sling attachment point is normally adjustable forward or backward on the fore end of the rifle.

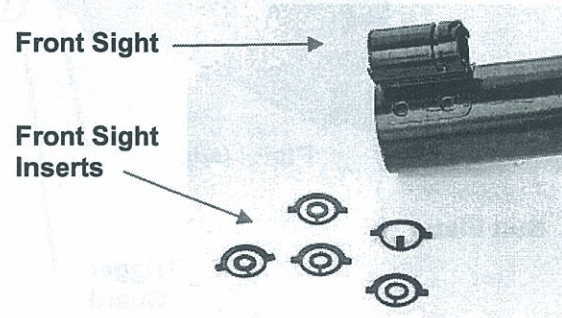
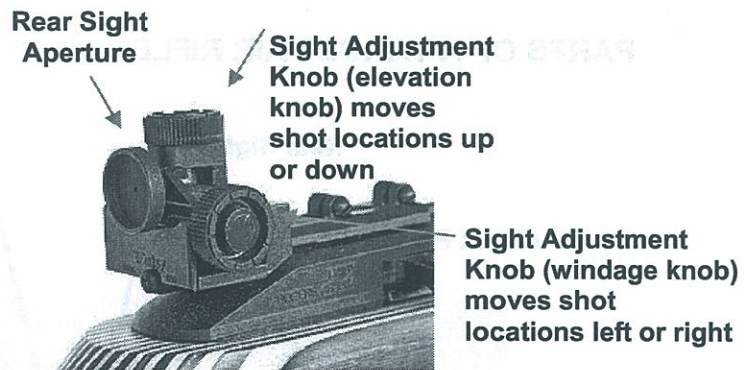



## TARGET SHOOTING EQUIPMENT AND CLOTHING

Only a few items of special target shooting equipment are needed for basic marksmanship training and the first levels of competition. The equipment that is used protects the shooter, assists in holding the rifle steadier, or makes shooting more comfortable.

- **Sling.** A web (or leather) strap that attaches to the fore end of the rifle and has a loop that fits around the upper arm. The sling must be used in the prone and kneeling positions, but cannot be used in the standing position. When properly adjusted so that it is tight, the sling helps to hold the rifle steady.

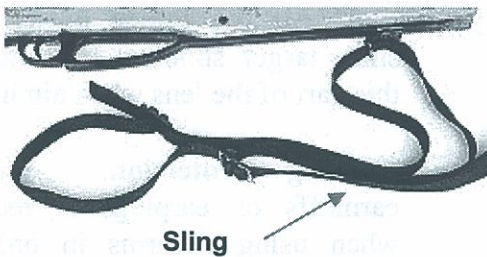

Sling

- **Glove.** Target shooters wear a glove on the hand that supports or holds the rifle. The glove protects the hand from the pressure of the sling when firing in prone and kneeling positions and allows the rifle to rest more comfortably on the hand while holding the rifle in standing position.

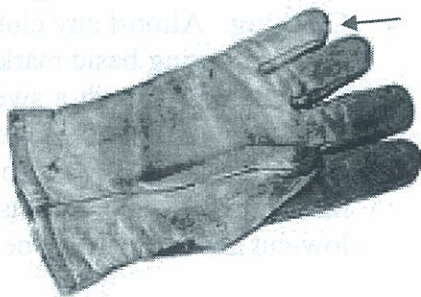

Glove

- **Kneeling Roll.** A cylindrical cushion that target shooting rules allow to be placed under the ankle when firing in the kneeling position. The kneeling roll provides stability and comfort to the body in that position. The roll may not exceed 10 inches in length and 7.2 inches in diameter.



Kneeling Roll

- **Shooting Mat.** A mat that target shooting rules allow shooters to lie on when firing from the prone or kneeling position.

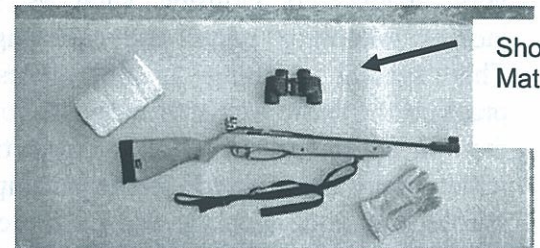

Shooting Mat

- **Rear Sight Blinder.** An attachment that is often used on the rear sight to block the view of the non-aiming eye. Blinders are usually homemade from cardboard or a strip of plastic cut from a milk carton. They can be no more than 30mm high and 100mm wide.

Rear Sight  
Blinder

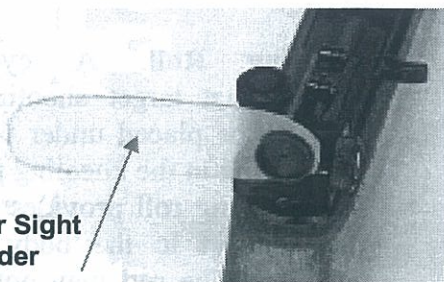

## PELLET HANDLING, PERSONAL CLOTHING, AND EQUIPMENT

Pellets are made of lead, which is a toxic substance that must be handled with care. However, medical tests have shown that that air rifle shooters, when they take reasonable precautions do not face any health risks. These precautions are:

- **No food on the range**
- **No open beverage containers**
- **Wash hands in cold water after handling pellets**

Advanced competition shooters wear very specialized clothing such as shooting jackets, shooting pants and shooting boots. This special clothing is not necessary to practice the basic skills of target shooting. In fact, in sporter class air rifle competitions in which many JROTC rifle teams participate, this specialized equipment is not permitted. The following items of personal clothing and equipment are the minimum required for a safe, comfortable target shooting experience.

- **Eye Glasses or Safety Glasses.** One of the most important requirements for a target shooter is to be able to see well. Anyone who normally wears eyeglasses should wear them during shooting. Many champion shooters wear corrective lenses so there is absolutely no disadvantage to anyone who wears glasses. There is also an extremely remote chance that a lead pellet fragment will bouncing back to the

firing line. For this reason, it is recommended that all air rifle shooters wear either their personal eyeglasses or safety glasses to provide full protection for their eyes.

Hearing  
protection  
(foam ear  
plugs)



Safety  
glasses or  
eyeglasses

Safety glasses used for shooting should have a clear, distortion free area near the bridge of the nose since target shooters look through this part of the lens when aiming.

- **Hearing Protection.** Wearing earmuffs or earplugs is required when using firearms in order to protect against hearing loss caused by loud impulse sounds. Air rifles generate much less sound and hearing protection is not required to protect against noise generated by air rifles. Some air rifle shooters, nevertheless, wear earplugs to reduce the sounds of air rifle firing and to help them concentrate.
- **Clothing.** Almost any clothing may be worn during basic marksmanship instruction, although a sweatshirt or long-sleeved shirt is preferred. In sporter class air rifle competitions, a maximum of two sweatshirts and low-cut shoes only may be worn.



Sweatshirt or long-sleeved shirt

## LOADING AND FIRING AN AIR RIFLE

To fire air rifles at targets, it is necessary for shooters to know how to charge, load, and fire them. Depending upon the type of air rifle used, there are three or four steps in doing this.

- **Step 1 – Open the Bolt.** The first step in loading and firing an air rifle is to open the bolt or loading port of the action. Opening the bolt cocks the trigger and firing mechanism.
- **Step 2 – Charge the Air Chamber.** This step is not necessary if a compressed air or CO<sub>2</sub> air rifle is used. With pneumatic air rifles such as the Daisy M853, charge the air chamber by opening and fully extending the cocking lever. Pause for a second to allow air to fully enter the chamber and then close the charging lever. Target air rifles such as the M853 cannot be double-charged. When the air chamber is charged by working the cocking lever once, opening the cocking lever again will simply release the air from the chamber and the chamber must be charged again by closing the charging lever.

- **Step 3 – Load Pellet.** To load a pellet in the Daisy M853 or M888, place the pellet in the loading port. Then push the bolt forward to seat the pellet in the breech end of the barrel. With precision air rifles the pellet is seated directly into the breech end of the barrel.
- **Step 4 – Release Trigger.** With the loaded rifle pointing at the target, the shot is fired by smoothly pressing the trigger to the rear until the firing mechanism is released.
- **Dry Firing.** Dry firing is done by opening and closing the bolt or cocking mechanism without either charging the air chamber or loading a pellet. With a cocked, but unloaded, air rifle it is possible to simulate firing a shot. This simulation or dry firing is one of the best ways to learn and practice proper shooting techniques.



Cock the pneumatic air rifle by opening and fully extending the cocking lever. Wait one second and then close the lever.

To load the Daisy M853/M888, place a pellet in the loading port and close the bolt by pushing it forward.

Complete loading by pushing bolt forward to seat pellet in breech

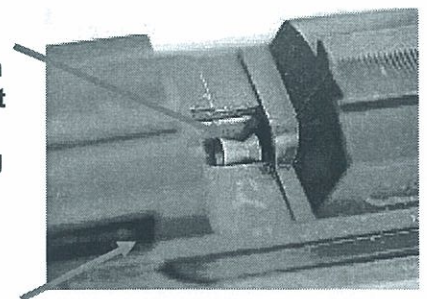

To load the precision air rifle, fully seat the pellet in the breech end of the barrel with the finger or thumb.

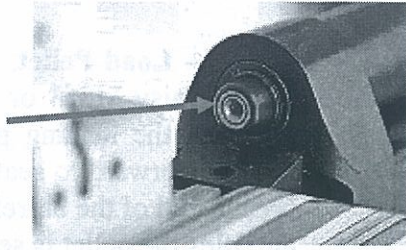

### CONCLUSION

After you learn the essential parts and components of the air rifle you will be using and how to load and fire it, you are ready to learn the first skills of target rifle marksmanship.



LOADING AND FIRING AN AIR RIFLE

### LOADING AND FIRING AN AIR RIFLE

To fire an air rifle, you must first load it. To load the rifle, you must first open the breech. To open the breech, you must pull the cocking lever back. This action compresses the air in the chamber. When the air chamber is charged, you can load a pellet. To load a pellet, you must place it in the breech and push it forward until it is fully seated. Once the pellet is seated, you can close the breech and fire the rifle.

Step 1 - Open the Breech. The first step in loading an air rifle is to open the breech. To do this, you must pull the cocking lever back. This action compresses the air in the chamber. When the air chamber is charged, you can load a pellet.

Step 2 - Charge the Air Chamber. This step is the second step in loading an air rifle. To charge the air chamber, you must pull the cocking lever back. This action compresses the air in the chamber. When the air chamber is charged, you can load a pellet.

Step 3 - Load the Pellet. The third step in loading an air rifle is to load the pellet. To load a pellet, you must place it in the breech and push it forward until it is fully seated. Once the pellet is seated, you can close the breech and fire the rifle.

Step 4 - Fire the Rifle. The fourth step in loading an air rifle is to fire the rifle. To fire the rifle, you must pull the trigger. This action releases the compressed air, which propels the pellet forward. Once the pellet is fired, you can pull the cocking lever forward to reset the rifle for the next shot.

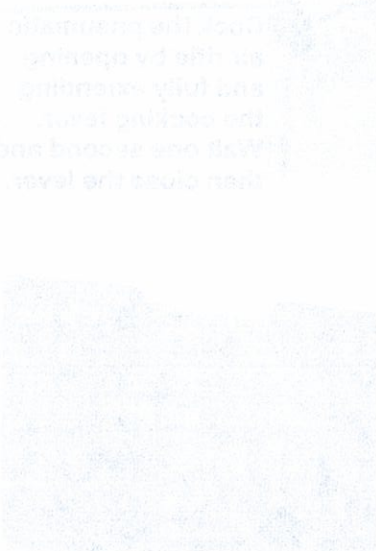

To load the  
rifle,  
pull the  
cocking lever  
back to  
charge the  
air chamber.  
Then, place  
the pellet in  
the breech  
and push it  
forward  
until it is  
fully seated.  
Once the  
pellet is  
seated, you  
can close  
the breech  
and fire the  
rifle.

## LESSON 4: AIMING BASICS AND THE FIRST TARGET POSITION - STANDING

### PURPOSE

This lesson introduces you to the first target position, which is the standing position.



*dry fire  
sight alignment  
standing position  
target  
trigger release*

### INTRODUCTION

Target rifle shooting involves firing in three different shooting positions, standing, kneeling and prone. These shooting positions originated with firing positions that once were taught to soldiers and hunters. Today, these traditional firing positions have evolved into specific shooting positions that are part of target shooting and are defined by competition rules recognized throughout the world.

### SHOULD I SHOOT RIGHT- OR LEFT-HANDED?

Before you begin to shoot in any shooting position, you must decide whether you will shoot from your right or left shoulder and aim with your right or left eye. The best way to determine whether to shoot right-handed or left-handed is to determine which eye is your dominant or master eye. Someone whose right eye is dominant should shoot from the right shoulder. Someone whose left eye is dominant should shoot from the left shoulder.

A simple dominant eye test should be performed to determine which eye is dominant. Cut a one-half inch hole in a 3"x5" card. Hold the card at arm's length. With both eyes open, look through the hole at a distinct object. Then bring the card back to your eyes while continuing to look at the object. If you continue to look at the object with both eyes open, the hole in the card will end up in front of your dominant eye.

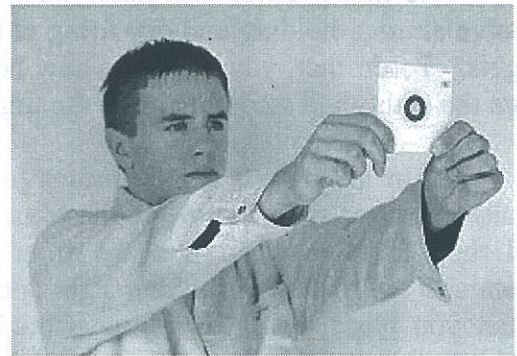

*Dominant eye test--Step 1*



*Dominant eye test--Step 2*

There are also many people who are cross dominant. That is, they are right-handed and left-eye dominant or vice versa. There is some research that indicates cross dominant individuals may advance further in target shooting if they shoot from the same shoulder as their dominant eye, but the research is not conclusive.

For cross dominant persons who simply are not comfortable shooting from the same shoulder as their dominant eye, shooting from the other shoulder is acceptable. However, if this is done, it is very important to place a blinder on the rear sight to block the view of the dominant eye so that the eye that is used for aiming can concentrate on the rifle sights.

**AIMING- SIGHT ALIGNMENT**

The first practice exercises you will do involve aiming, holding and dry firing at blank targets. To do that, you need to know how to align the sights and smoothly press the trigger.

**Sight alignment** simply means to look through the rear sight iris to see the front sight and then to align it so that the front sight appears in the middle of the rear sight opening. When you place the rifle in your shoulder to hold it in the standing position, place your head on the cheek piece so that the eye you use to aim looks through the small hole in the rear sight. As you look through this hole, you should automatically see the front sight. To achieve proper sight alignment, simply move the front sight so that it appears in the center of the rear sight.

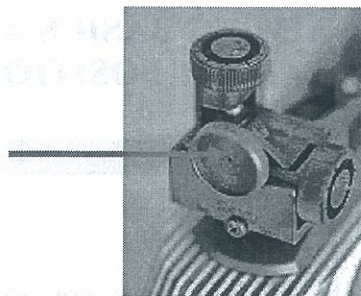

*To align the sights, look through the small hole in the rear sight iris to see the front sight*

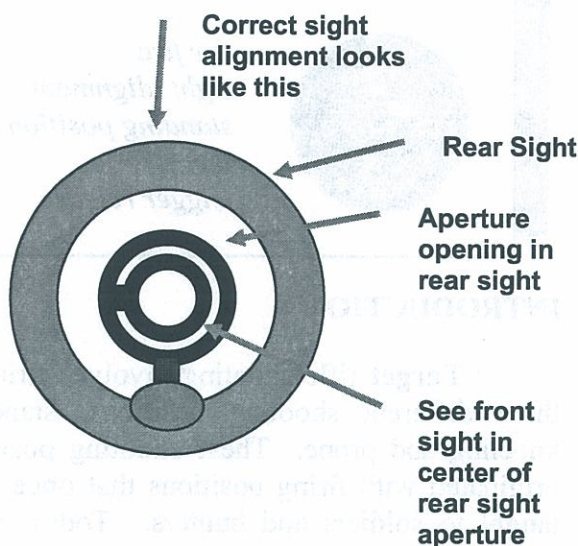

**PULLING THE TRIGGER**

To **dry fire** while aiming at a blank target, it is necessary to first cock the trigger mechanism without charging the gas cylinder or loading a pellet in the breech. After the cocked rifle is placed in the shooting position, the shooter looks through the rear sight to properly align the front and rear sights, points the aligned sights at the center of the target and then completes the dry fire shot by smoothly pressing the trigger.

Some important points to master in correctly pulling the trigger are shown in the following illustrations.

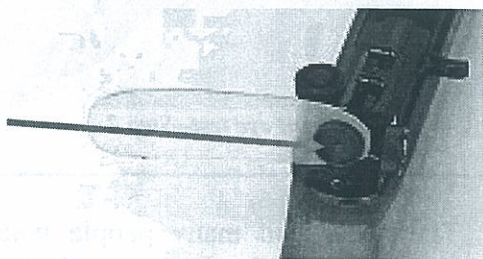

*A rear sight blinder can be made from a piece of translucent plastic. Cut a hole in one end so that the blinder will fit over the detached rear sight iris*

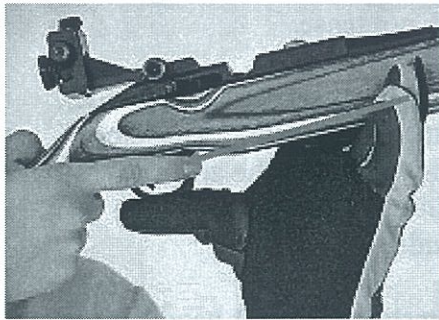

When you place the rifle in position, always keep the index finger outside the trigger guard.



Align the sights on the target and then place the index finger on the trigger.

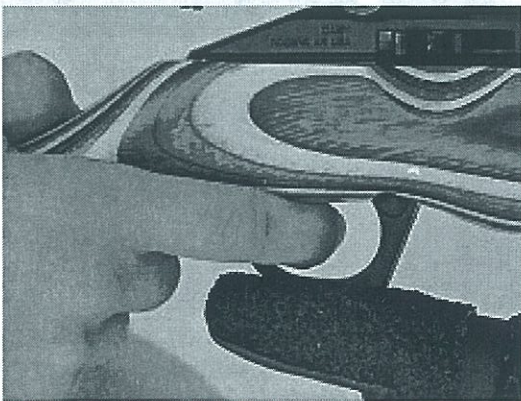

Take up the slack (first-stage) on the trigger and then, with the sights aligned on the target, smoothly press the trigger to the rear until the mechanism releases.

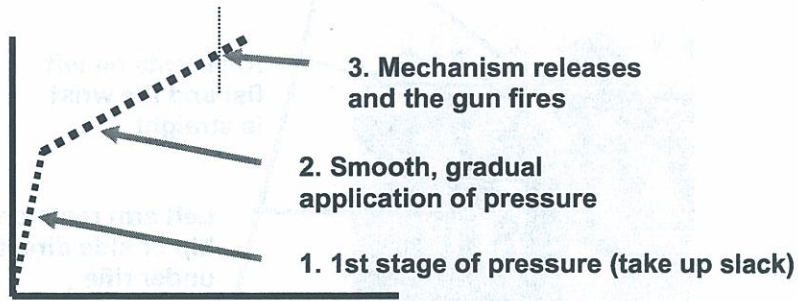

The graph shows how pressure is applied to the trigger. The y-axis represents pressure and the x-axis time. The time from the first application of pressure until the mechanism, releases should last about 4-8 seconds.

### STANDING POSITION DESCRIPTION

The first shooting position normally taught in the JROTC rifle marksmanship is the **standing position**. The photos below show both a champion shooter and a high school shooter firing in the standing position. The champion shooter was a competitor in the 2000 Olympic Games and won a bronze medal in the women's air rifle event. She is firing a precision air rifle and wearing special clothing that is used in advanced target shooting. The other shooter is firing a sporter air rifle and wearing the type of clothes that are used in school-age sporter class competitions.

**Special Note.** The shooting position illustrations and descriptions in this Student Text are given for right-handed shooters. If you are a left-handed shooter, simply reverse the descriptions or visualize holding the rifle with hands opposite those that are shown.

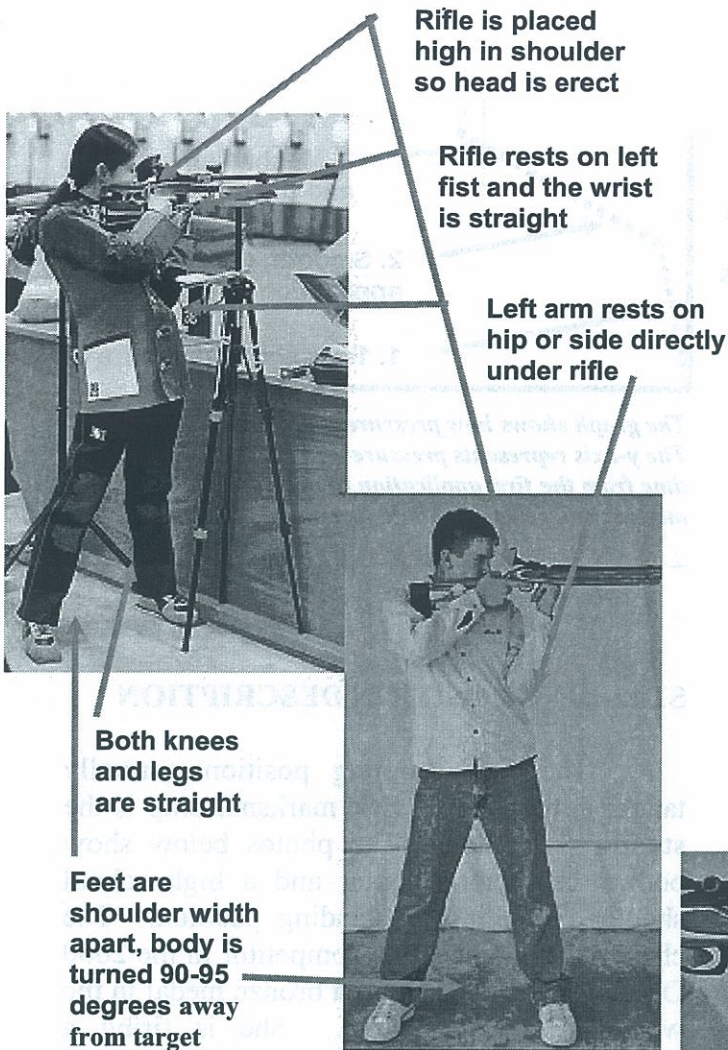

3. Both legs and knees are straight. However, the muscles in the legs must be relaxed, not tense.
4. The left arm must rest on the left side, directly under the rifle. The elbow can rest on the hip, or the arm can rest on the side, but it must always be directly under the rifle.
5. The rifle rests on the left hand. Most shooters make a fist with their hand and rest the rifle on the fist. There are different support hand positions that are correct for different individuals.
6. The rifle should be placed fairly high in the shoulder so that the head can be kept nearly erect. Choosing the correct support hand position makes this possible.

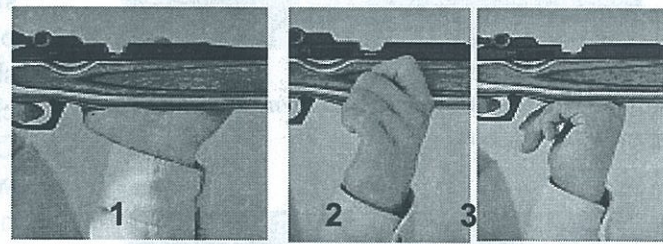

*Notice how similar the two standing positions are. Visualize yourself in this same stance as you hold an air rifle while aiming at a target. Study the two photos carefully. The arrows point to specific things you should try to copy when you shoot in the standing position.*

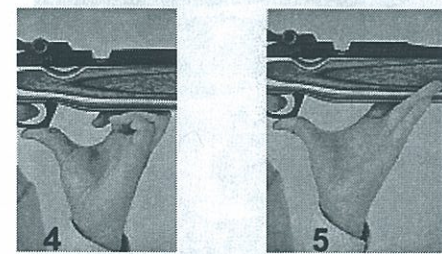

The most important points about the **standing position** that you should try to duplicate in your standing position are:

1. The feet and body are turned so that the body faces at least 90 degrees away from the target and the left side is pointed towards the target.
2. The feet are shoulder width apart.

**Illustrations 1-5 show different support hand positions for standing, from the lowest (open hand #1) to the highest on the (thumb and split fingers #5). Note that the wrist is bent only in the open hand position. The wrist must be held straight in all other hand positions.**



The correct support hand position for you is the one that raises the rifle up to the level of your eye and the target. You should not simply copy the left hand position of another shooter. The relative lengths of your arms and torso determine the correct hand position variation for you. The illustrations here show different support hand variations for standing. These include the lowest hand position, for shooters with proportionately long arms or short torsos, as well as the highest hand position, which is best for shooters with long torsos and shorter arms. Select a support hand position for you that will raise the rifle so it is fairly high in the shoulder and your head is nearly erect.



*One of the most critical points in building a correct standing position is to place the left (support) arm on the side of the body, directly under the rifle. When this arm is relaxed on the side of the body, the forearm serves as a steady brace to support the rifle. In shooting, bone support is much steadier than muscle support.*

The standing position is the first shooting position that is taught because it is both the easiest shooting position to learn and the most challenging to master. The position is especially challenging because it has a smaller base of support and the body is higher. It is normally not as stable as the lower prone and

kneeling positions where a sling can also be used to help stabilize the rifle. Slings may not be used in standing. Most shooters find that it takes more practice to develop the ability to hold the rifle still in standing.

Notwithstanding the challenges of developing a stable standing position, the position can produce amazing scores. The current women's world record for air rifle standing on the official competition target (the ten ring is a 0.5 mm dot that is about the size of the period at the end of this sentence) is a perfect 400 out of 400 possible points. The men's world record is 600 out of 600 points.

## LEARNING THE STANDING POSITION

Now, with a knowledge of what a proper standing position looks like, how to determine whether you should shoot right or left handed, how to select the proper support arm position, how to align the sights and how to release the trigger, you are ready to try the standing position yourself. Learning the standing position is easier if it is done in a sequence that follows these steps:

1. **Study the position.** Take one more look at the standing position photos. Study those model standing positions and visualize how you will place your body in the same position.
2. **Get into position without the rifle.** Take your position on the firing point and get into a standing position without the rifle. By doing this first without the rifle, it will make it easier to get your feet in the correct position and place your support arm on the side of the body correctly. Key position checkpoints are marked with arrows on the photo. Stand with your feet turned 90 degrees away from the target. Place

your feet about shoulder width apart. Keep your body relaxed, but erect and look toward the target with your head. Fold the left arm and rest it on your left side. Lift your right hand and imagine holding the rifle with it as the rifle rests on your left hand.

This is a good place to check your left hand position. The place where the rifle will rest should be at the same level as your chin (see dashed line on photo). If that support point is higher or lower, you should check lower or higher hand positions.

- 3. Get into position with the rifle.** The next step is to pick up the rifle and get into the same position with the rifle. When you add the rifle to the position, begin by placing the rifle fairly high in your shoulder. The placement of the rifle butt plate in the shoulder is correct if the head is erect. If the head is bent down, the rifle is too low in the shoulder. Check the support arm position to be sure it rests on your side. A good way to check this is to be sure your arm is completely relaxed and that no muscles in the arm are used to hold up the rifle. Finally, check your left hand position. If the rifle is pointing below the target, try a higher hand position. If the rifle is pointing above the target, try a lower hand position.

**Support point for rifle is at chin level**

**Arm rests on side**

**Buttplate is placed high to keep head erect**

**Left hand position raises rifle to level of target**



**Feet turned 90 degrees, placed shoulder width apart.**

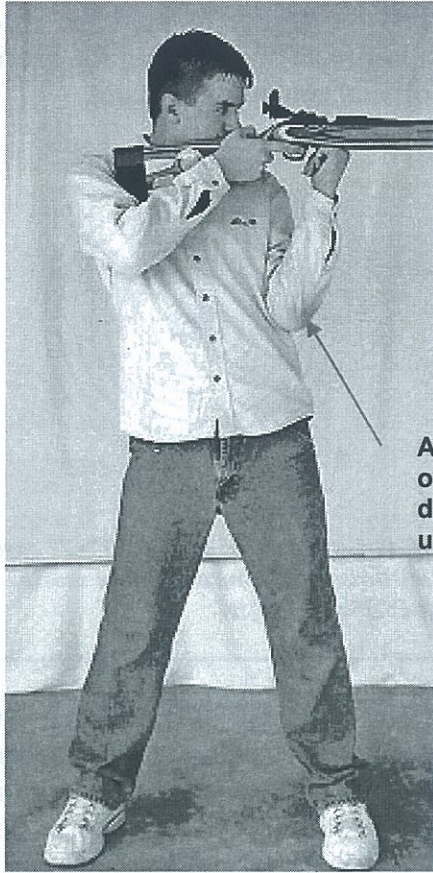

Arm rests on side directly under rifle

**4. Supported position option (not shown).**

Many instructors will use this option with new shooters to familiarize them with the basics of shooting prior to moving to the standing position. In this position the rifle or hand holding the rifle, is supported on a sandbag rest or kneeling roll. Shooters can fire from either the prone supported position or while sitting behind a table with the rifle or fore arm supported by sandbags or kneeling roll. In this manner instructors can focus on teaching aiming, breath control, trigger control and site alignment. As soon as the instructor believes the student is ready they will move the student to the standing or other approved position.

**CONCLUSION**

This lesson details the correct way to achieve the standing position. Remember, all photos used in this lesson are for right-handed

shooters, so if you are a left-handed, reverse the descriptions. When learning the standing position it is important to learn in steps. Study a model position first, then try the position without the rifle. Next try the position with the rifle and finally do holding and dry fire exercises on a blank target before advancing to a bull's eye target.

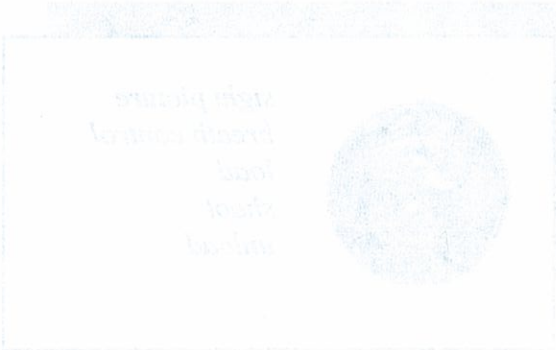

## LESSON 5: AIMING AND FIRING

### PURPOSE

This lesson introduces you to the basic techniques for firing an aimed shot, at a target.



*sight picture  
breath control  
load  
shoot  
unload*

### INTRODUCTION

After you have learned how to assume the standing position and have dry fired several times at a blank target you are ready to prepare for live firing at actual targets. **Aiming** and firing actual shots at a target involves learning about some additional elements of target shooting that are covered in this chapter. These include targets, aiming and sight picture, proper breathing and the coordinated technique of firing the shot. Developing a good shot technique is a critical factor for target shooters because it involves combining and coordinating the complex and simultaneous actions of aiming, breathing, holding and trigger control.

### TARGETS FOR AIR RIFLE SHOOTING

Two different targets are used in JROTC three-position air rifle shooting. The first target that is used is designed for marksmanship instruction. It is called the BMC (Basic Marksmanship Course) target. The BMC target has large scoring rings that are appropriate for new shooters who have not yet

developed the ability to hold the rifle steady enough to fire all shots within the scoring rings of the official competition target.



*The BMC target is printed on a 6 1/2"x7" card, has a 15.25mm 10-ring and nine additional scoring rings that are each 15.25 mm larger.*

The second target that will be introduced at the end of basic marksmanship instruction is the official competition target. The International Shooting Sports Federation and target shooting organizations all over the world recognize the scoring ring dimensions on this target as official for their competitions. In the U. S. these targets are often printed so that ten competition or record targets and two practice targets appear on one target card. These targets are called "ten-bull targets."

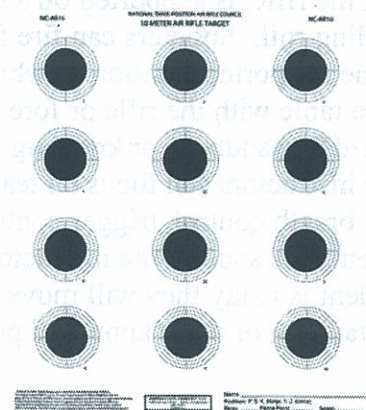

*The official 10-meter air rifle "ten-bull target" is printed on an 8 1/2" x 12" card. Each of its ten record and two practice targets have 0.5mm 10-rings (dots).*

The much larger scoring rings on the BMC target are designed so that the shots fired by beginner shooters will still hit the target. After a few weeks of practice, all shooters will develop the ability to hold their rifles steadier and fire more accurately so that they can graduate to the official target. The official ten-bull target is the target that is most often used by JROTC and high school rifle teams for three-position air rifle competitions.

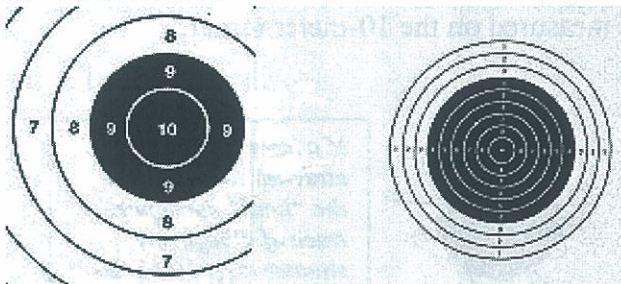

*A comparison of the relative sizes of the scoring rings on the BMC and official air rifle targets. The size of the black area or aiming bull is the same on both targets.*

### BREATH CONTROL

When you practiced holding an air rifle in the standing position on a blank target, you may have noticed that if you stop breathing while aiming you can hold the rifle steadier. To shoot rifles accurately, it is in fact, absolutely necessary to stop breathing while

aiming and releasing the trigger. This is the only way to make it possible to hold the body still enough to consistently shoot tens on the official air rifle target.

Exhaling the breath is also a good way to help the body relax to calmly prepare to fire an accurate shot. To control your breath while firing a shot, simply breathe normally and then exhale naturally. Stop breathing after the breath is exhaled and hold your breath until the shot is fired. The breathing cycle for shooting should look like the illustration at the bottom of this page.

### AIMING AND SIGHT PICTURE

To develop the ability to shoot high scores on targets, it is necessary to learn how to aim with great precision. Your first practice in the standing position involved dry firing at blank targets where it is not possible to aim accurately because there was no bull's-eye to aim at. With a bull's-eye to aim at, it is possible to attain a complete sight picture and to aim very accurately by following two simple steps:

- **Step 1—Sight Alignment.** You have already learned to align the sights by looking through the rear sight to see the front sight centered in the rear sight opening. The first step in attaining a complete sight picture is to align the sights.

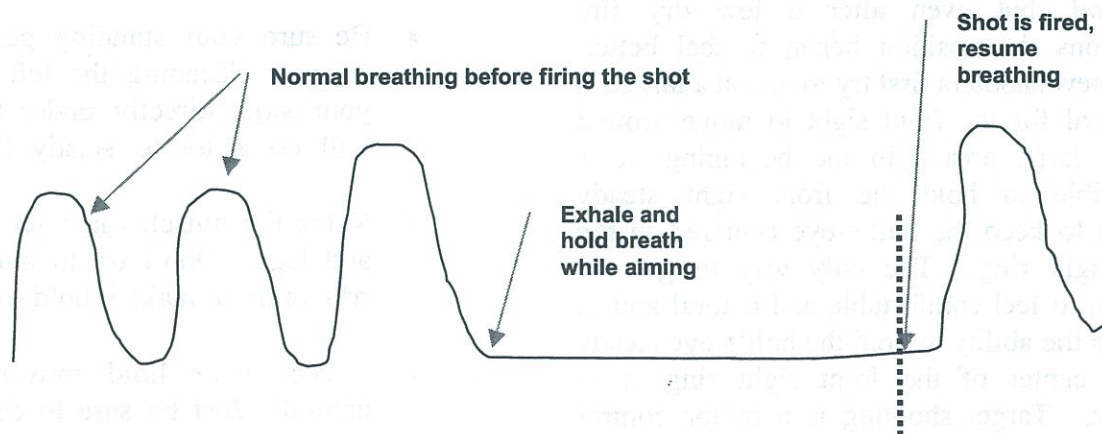

### Sight Alignment

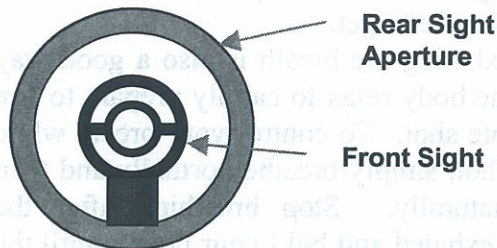

- **Step 2—Sight Picture.** After aligning the sights, all that is needed to complete the sight picture is to point the aligned sights at the target so that the bull’s-eye appears in the center of the front sight aperture.

### Sight Picture

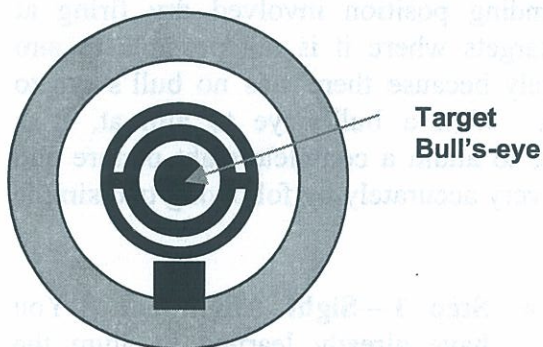

### HOLDING STEADY

When you first held the rifle in the standing position it probably felt awkward and unnatural, but even after a few dry fire repetitions the position began to feel better. When new shooters first try to aim at a target, it is normal for the front sight to move around over a large area. In the beginning, it is impossible to hold the front sight steady enough to keep the bull’s-eye centered in the front sight ring. The only way to get the position to feel comfortable and natural and to develop the ability to hold the bull’s-eye steady in the center of the front sight ring is to practice. Target shooting is a motor control

skill where steadiness with the rifle can only be developed by practice.

It is natural to have some movement of the front sight aperture around the bull’s-eye while aiming. The area or magnitude of this movement is called a shooter’s “hold.” As a beginner shooter, your hold may be quite large, covering much of the target. With practice, you will see that your hold gradually becomes much smaller and smaller. Champion shooters, in fact, develop hold movements that are no larger than three or four millimeters when measured on the 10-meter target.

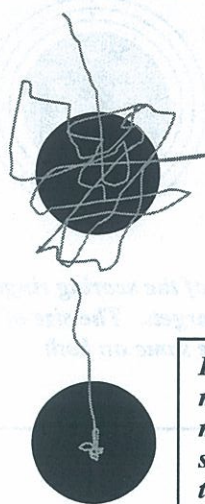

*If a laser pointer were attached to the barrel, the “hold” movement trace of a beginner shooter might look like this.*

*Practice will make the hold movement trace of every shooter much smaller. Champion shooters are able to hold within the area of the ten ring on the official air rifle target.*

The steadier you learn to hold your rifle, the higher your scores will be. Here are a few tips to practice that will help you hold your rifle as steady as possible.

- Be sure your standing position is correct. Keeping the left arm on your side, directly under the rifle will do a lot to steady the rifle.
- Relax the muscles in your left arm and legs. Don’t try to muscle the rifle to try to make it hold steadier.
- Accept your hold movement as natural. Just be sure to center the

entire hold movement over the bull's-eye.

- Concentrate on your sight picture. Think about letting the hold movements become smaller and keeping the bull's-eye movements inside the front sight ring.

**FIRING THE SHOT**

Firing the shot involves putting all these separate elements or techniques together. This is called the shot technique. The shot technique includes:

1. Loading the rifle.
2. Lifting the rifle into position.
3. Aiming by first seeing the front sight in the center of the rear sight (sight alignment) and then by bringing the front sight aperture onto the bull's-eye (sight picture).
4. Taking one or two more breaths, exhaling and then holding the breath until the shot is fired.
5. Centering the hold movements of the front sight over the bull's-eye.
6. Smoothly pressing the trigger while the hold movements are centered.



*Proper shot technique begins with loading and placing the rifle in position. Shot technique also includes aiming, breath control, hold control and trigger control.*

Visualize how you will combine aiming, breathing, relaxing, keeping your rifle's hold movements centered over the target and smoothly pressing the trigger into a coordinated series of actions. And remember again, developing the skills to hold a rifle steady and execute good shot technique comes from practice.

**SHOOTING GROUPS ON THE TARGET**

The range firing exercises that are done as part of this basic marksmanship lesson are very important because they are the first live firing that you will do at actual targets. Here are some things to remember as the instructor or range officer guides you through your first experience in shooting at bull's-eye targets from the standing position.

*A graphic representation of the different elements or techniques of firing the shot and how they are coordinated during the 15-20 second period when the shot is fired might look like this.*

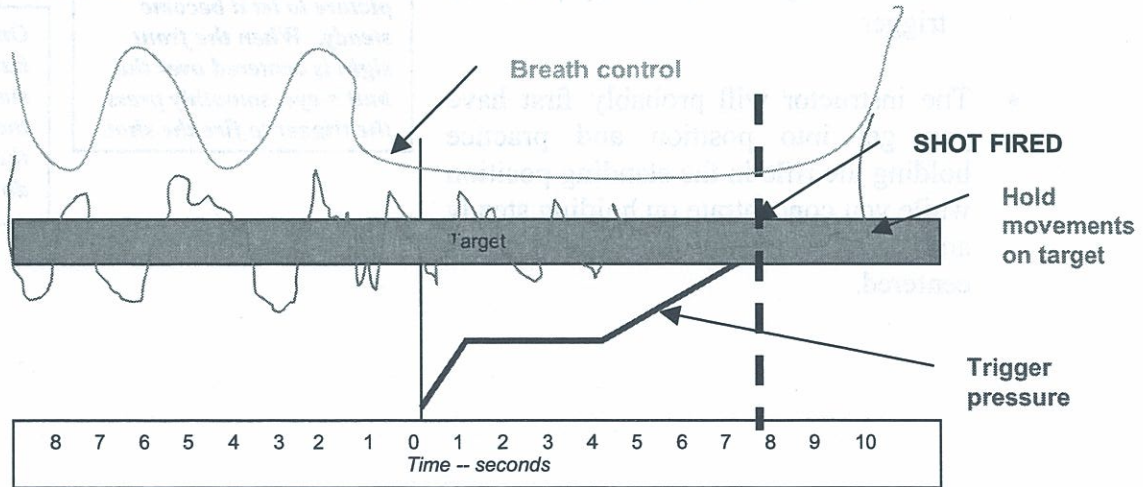

- **Range Commands/Instructions.** Be sure to follow the instructions of the instructor or range officer. Move to the firing line and pick up the rifle when told to do so. Do not load or begin to fire until the commands **LOAD** and **START** are given.
- **Standing Position.** Use the same standing position that was taught and practiced in the previous lesson.
  - Turn your body 90 degrees away from the target and stand with your feet shoulder width apart.
  - Be sure your left arm rests on your side or hip so that it is directly under the rifle.
  - Be sure you are using a support hand position that allows the rifle to be placed high enough in the shoulder that your head is erect.
  - When you begin to aim, take one or two more breaths, exhale, and stop breathing.
  - Relax your left arm and legs and let the rifle's hold movements settle down.
  - Center the front sight movements over the bull's-eye and smoothly press the trigger.
- The instructor will probably first have you get into position and practice holding the rifle in the standing position while you concentrate on holding steady and keeping your hold movements centered.

- Next the instructor will have you simulate firing the shot by making several dry fire repetitions.
- When you are instructed to load and fire the rifle, the instructor will have you shoot a series of shots (usually five shots).
- When you finish firing, be sure to open the bolt on your rifle, place it on the floor and insert a CBI in the barrel. Stand by until the instructor checks to be sure your rifle is safe and gives further instructions.
- The objective of this first firing exercise is to shoot a "group" of shots. At this point it does not matter whether your shots are in the center of the target. The smaller your group of shots is the better you have done. You will be taught how to adjust the sights on your rifle so that your shot groups will hit the middle of the target in the next lesson.

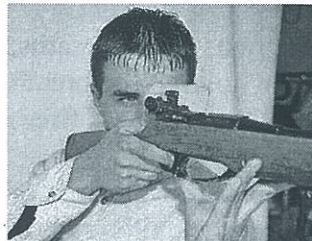

*When firing the shot, a key is to concentrate your attention on the sight picture to let it become steady. When the front sight is centered over the bull's-eye, smoothly press the trigger to fire the shot.*



*One of the keys to having a steady hold in standing is making sure the left arm is relaxed so that it rests on the side directly under the rifle.*





## LESSON 6: SIGHT ADJUSTMENT AND SCORING

### PURPOSE

This lesson introduces you to correct sight adjustment and scoring.



zeroing  
calculate  
evaluate  
score  
sight zero

### INTRODUCTION

During your previous range firing sessions you shot five-shot groups (series of five shots) in the standing position. This practice helps you become more comfortable with the position as well as to learn and coordinate the different actions involved in the technique of firing a shot. After you fire several five-shot groups, your groups become smaller. You will soon reach a point where you and the other cadets in your marksmanship class want to know what **scores** you can fire. Shooting for score is, after all, one of the most interesting challenges of target shooting. Scoring your targets allows you to determine whether your latest score beat your previous day's best or perhaps a personal record.

In target shooting, shots that hit the central scoring ring, the ten ring, score the most points. Shots that hit each successive scoring ring outside of the ten ring, score one point less until shots in the last scoring ring count one and then no points. To score the highest number of points on any series of

shots, your shot groups must be centered on the target so that the ten ring coincides with the middle of the shot group.

The correct way to move shot groups to the center of the target is to adjust the sights so that the next groups fired are centered. This is called **zeroing** the rifle. Some cadets may have heard of "Kentucky windage" where a shooter aims away from the target center in an attempt to compensate for a rifle that is not zeroed. This means firing with an incorrect sight picture. That simply cannot be done consistently or with the kind of accuracy demanded in target shooting. If a shot group is not centered or zeroed, there is only one correct way to move the group to the center of the target. The sights must be adjusted.

In this chapter you will learn how to adjust the sights on your rifle to zero your shot groups. You will also learn the correct method of scoring targets so that you can determine the scores that you are firing

**Shots that hit the center or ten ring, score the most points**

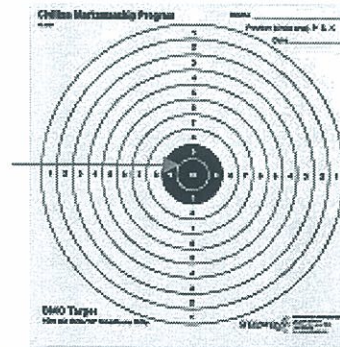

**Elevation**  
↓

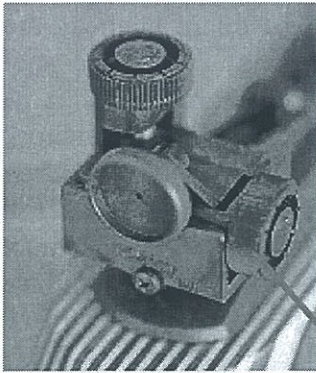

*When the shot groups fired with a rifle are off-center, the only correct way to move them to the center of the target is to adjust the rear sight by using the elevation and windage adjustments*

**Windage**

## HOW TO EVALUATE SHOT GROUPS

In your first live firing in the standing position, it is not important that your 5-shot groups be in the center of the target. However, no matter where they are located on the target, it is important to **evaluate** your shot groups to know how you are progressing. Here are some things to look for in evaluating your shot groups.

- **Overall size of the group** - the smaller your shot groups are, the better you are doing.
- **Shot group location** - if your shot groups are always in the same location on the target, that indicates your position and shot technique are consistent.
- **Wild shots** - if your shot groups have wild shots or “fliers” that are away from the main group, those shots indicate a mistake in shot technique was made on that shot.

**Excellent shot group, indicates good shooting performance**

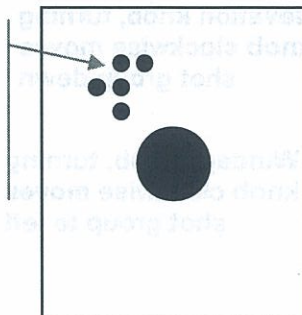

**“Flier” away from main shot group indicates a mistake in shot technique**

**Large shot group indicates need for improvement**

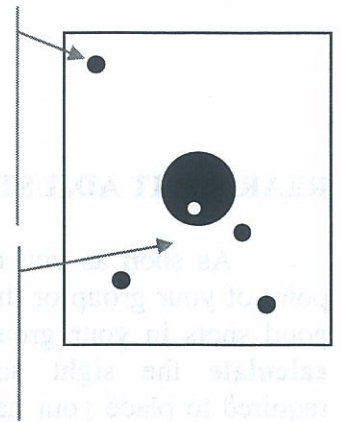

The next step in preparing to adjust your sights is to locate the center of your most recent shot group. Keep these points in mind as you determine shot group centers.

- Draw real or imaginary vertical and horizontal lines through the midpoints of the group.
- On shot groups with fliers, disregard any wild shots when determining the center of the group.
- Use the crossing point to mark the center point of the shot group.

**Draw vertical and horizontal lines through center of group**

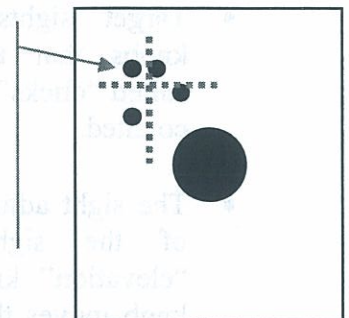

**Disregard fliers when determining center of group**

**Draw lines through center of main part of group**

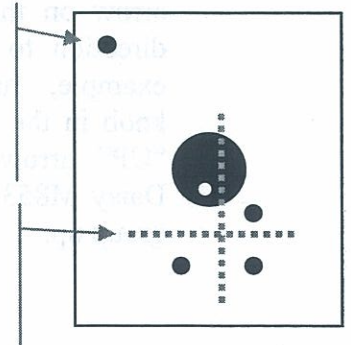

## REAR SIGHT ADJUSTMENT

As soon as you determine the center point of your group or the center point of the good shots in your group, you are ready to **calculate** the sight adjustments that are required to place your next shot group in the center of the target.

To calculate and make the necessary sight adjustments, you need to be familiar with your rear sight and how it works. The most common rear sight is the Daisy sight that is on most Daisy M853 and M888 air rifles. The El Gamo sight is used on Daisy M753 and Crosman M2000 air rifles. Precision air rifles have similar rear sights except that these sights have more precise (finer) adjustments and their adjustment knobs move shot groups in the opposite directions from the adjustment knobs on sporter air rifle sights. Note these things when examining the rear sight on the air rifle that you use.

- Target sights have adjustment knobs that turn in increments called “clicks” that can be felt and counted.
- The sight adjustment knob on top of the sight is called the “elevation” knob. Turning that knob moves the shot group up or down. Look for the direction arrow on the knob to see which direction to turn the knob. For example, turning the elevation knob in the same direction as the “UP” arrow (clockwise) on the Daisy M853 sight moves the shot group up.

- The sight adjustment knob on the side of the sight moves the shot group left or right when it is turned. It is called the “windage” knob. Look for the direction arrow on the knob to see which direction to turn the knob. Turning the windage knob in the direction of the “R” arrow (clockwise) on the Daisy M853 sight moves the shot group to the right.

- Each click of change on a sight moves the shot group center a uniform distance. Check the sight adjustment chart to determine how many clicks of elevation and windage it will take to move your shot group to the center. To move a shot group a distance equal to the distance between two scoring rings on the BMC Target, requires an adjustment of approximately 12 clicks.

Elevation knob, turning knob clockwise moves shot group up

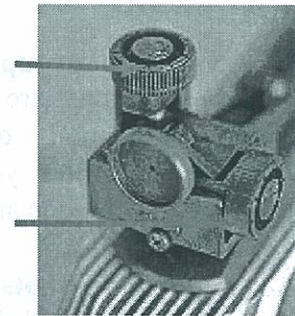

Windage knob, turning knob clockwise moves shot group to right

*The Daisy rear sight is commonly used on Daisy M853 and M888 air rifles.*

Elevation knob, turning knob clockwise moves shot group down

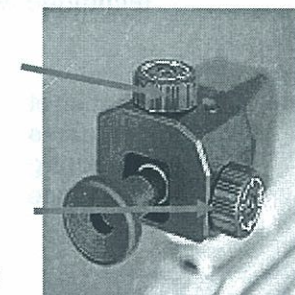

Windage knob, turning knob clockwise moves shot group to left

*Precision air rifle sights have more precise adjustments. Their elevation and windage knobs often have directions marked in German and move shot groups the opposite direction from the Daisy and El Gamo sights.*

### CALCULATING SIGHT ADJUSTMENT AND ESTABLISHING ZEROES

To calculate the sight adjustment needed to move your shot group to the center of the target, take the latest target you fired and locate the center of the shot group. Then calculate and make the necessary sight adjustments to correct your shot group by following these steps:

- Count the number of whole scoring rings from the horizontal line through the center of the group to the center of the target. In the illustration, this vertical distance is six scoring rings.
- Multiply the number of scoring rings in vertical distance times the number of clicks per ring for the target and sight you are using (use Sight Adjustment Chart). For a Daisy sight and the shot group in the illustration, the result would be 72 clicks (12x6).
- Turn the elevation knob on your sight, that number of clicks in the correct direction (down for group in illustration).
- Count the number of whole scoring rings from the vertical line through the center of the group to the center of the target. In the illustration, this horizontal distance is four scoring rings.
- Multiply the number of scoring rings in horizontal distance times

the number of clicks per ring for the target and sight you are using (Use Sight Adjustment Chart). For a Daisy sight and the shot group in the illustration, the result would be 48 clicks (12x3).

- Turn the windage knob on your sight, that number of clicks in the correct direction (left for group in illustration).

After making the necessary sight adjustments, fire another group to see if the sight adjustment is correct. One or two additional, smaller sight adjustments may be required to place your shot group in the center of the target.

Air Rifle Sight Adjustment Chart				
Sight	To move zero up, turn	To move zero right, turn	Clicks per scoring ring, BMC Target	Clicks per scoring ring, official target
Daisy	Clockwise	Counter-clockwise	12	2
El Gamo	Clockwise	Counter-clockwise	24	4
PRECISION, Anschütz, FWB, etc.	Counter-clockwise	Clockwise	30	5-6

*The click adjustment values given here are approximate and may vary with different sights.*

5 scoring rings to center

3 scoring rings to center

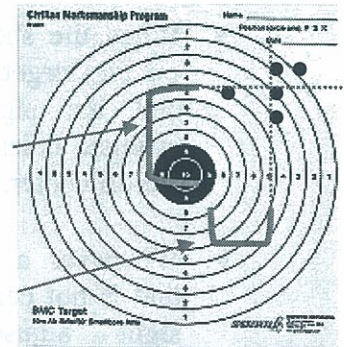

## BACKLASH

Backlash occurs on some sights and is when you change the direction of movement of your sights and the sight does not immediately respond in the new direction.

The sights on the Daisy 853/953 may have from one to three clicks of backlash. When you change the direction of movement, you must add the number of clicks needed to compensate for the backlash in your sights.

Since it may be different for each set of sights, you will have to determine the backlash on the rifle you are using. This can be done visually by observing the calibration scale when you change direction. In the beginning, all you really need to do is add two clicks when you change direction.

## THE SIGHT ZERO

A sight is “zeroed” when it is adjusted so that the center of the shot group is the same as the center of the target.

A sight is zeroed when the shot group is centered in the target

The highest possible scores can only be obtained if shot groups are centered

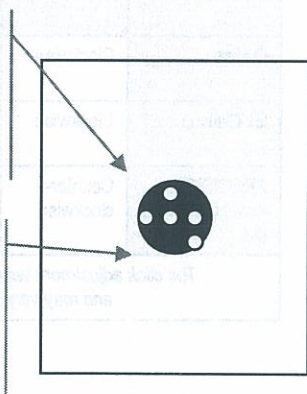

- When the shot group is centered on the target, the rifle is zeroed and the sight should not be changed unless subsequent groups are off center.
- Whenever a shot group is fired that is not centered, the necessary sight adjustments must be **calculated** and the adjustments made to the sight.

- Just because a sight is zeroed once does not mean it will stay zeroed. If a shooter’s position or shot technique changes, the shot group center will change.
- Just because a sight is zeroed for one shooter does not mean it is zeroed for other shooters who use that same rifle. Unless two shooters use exactly the same position and technique, their zeroes will probably be different.
- One of the most important skills a target shooter must develop is the ability to continually **evaluate** whether his/her rifle sight is zeroed and to make changes when necessary to keep the sight zeroed.

## HOW TO SCORE TARGETS

After you learn to adjust the sights on your rifle so that your shot groups are centered on the target, you are ready to learn how to properly score targets. There are only a few rules that control the scoring of targets.

- The first rule is that a shot is scored according to the value of the scoring ring that it hits. If a shot is in the seven ring, it **scores** seven points (see illustration, shot #1).
- The second rule is that if a shot hole cuts two or three scoring rings, the shot is scored according to the value of the highest scoring ring it hits. If a shot cuts both the nine and ten rings, it **scores** ten points (see illustration, shot #2).

- The third rule is that if a shot lies in one scoring ring, but just touches a higher value-scoring ring, the shot is scored according to the highest scoring ring that any part of the shot hole touches. If a shot is in the eight ring, but just barely touches the nine ring, it **scores** nine points (see illustration, shot #3).

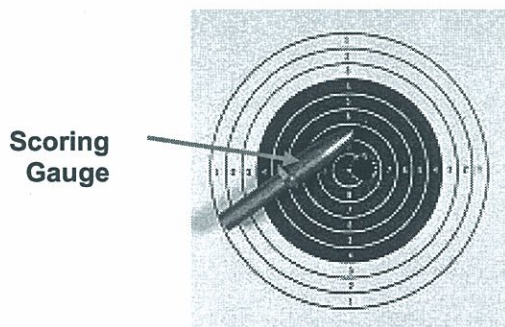
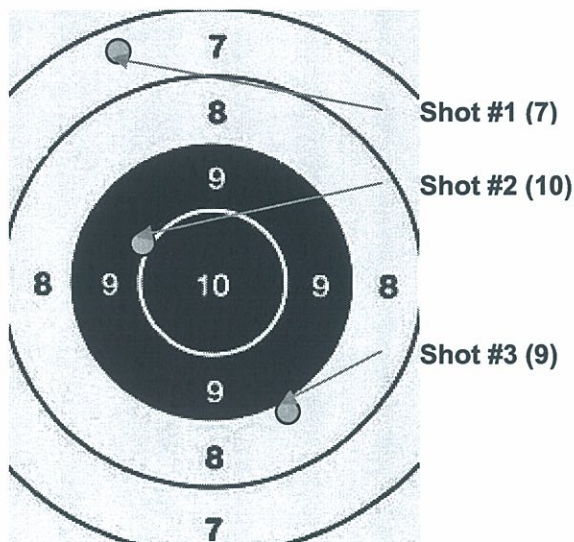

*In official scoring, a scoring gauge is used to determine whether a doubtful shot touches a higher value-scoring ring.*

- The fourth rule is that if it is doubtful whether a shot hole touches a higher value scoring ring, a scoring gauge should be used. When the scoring gauge is used with a magnifying glass, it allows the scorer to see exactly where the edge of the shot hole is

and assists in determining the correct score for that shot. If a scoring gauge is not available, it is important to look carefully at the edge of the shot hole and to also use a magnifying glass to determine whether the edge of the hole touches a higher value scoring ring.

- The total score for a target is the total value of all shots on the target. At first you will fire five-shot groups where the maximum score is 50 points. Soon you will fire ten shots on a target where the maximum score for the target will be 100 points.

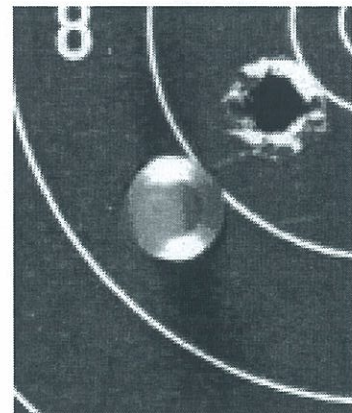

*When a scoring gauge is inserted in a shot hole, it is possible to see exactly where the edge of the shot hole lies.*

**Lost Points Scoring Method:** It is generally faster to add up points lost on each shot rather than the total score. This is known as the Lost Points Scoring Method (LPSM). Using the LPSM you add the number of points lost and subtract from the number of possible points. In the example to the left shot #1 would be a 3; shot #2 would be a 0 and shot #3 would be a 1 for a total of 4. Subtract that total from the most possible points, 30, and you get 26 for the score.

### CONCLUSION

In your next range firing exercises, you will have an opportunity to adjust your sights so that your shot groups hit the center of the target. With your shot groups centered, it is then possible to score your targets so that you can begin to make records of your progress as a shooter.

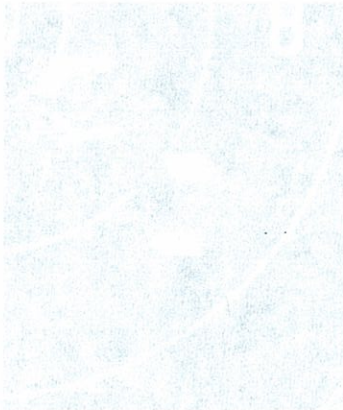

When a shooter's shot group is centered in the bullseye, it is possible to score your target.

Your target's scoring is generally based on the number of points that you score. The number of points that you score is based on the number of points that you score. The number of points that you score is based on the number of points that you score.

The first rule is that you should always use the same target for all of your shots. This is because you want to be able to compare your shot groups and see how they are changing. You should also use the same target for all of your shots.

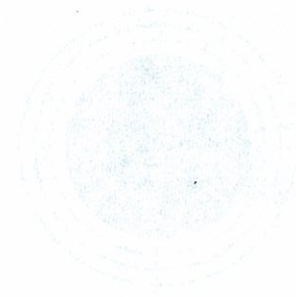
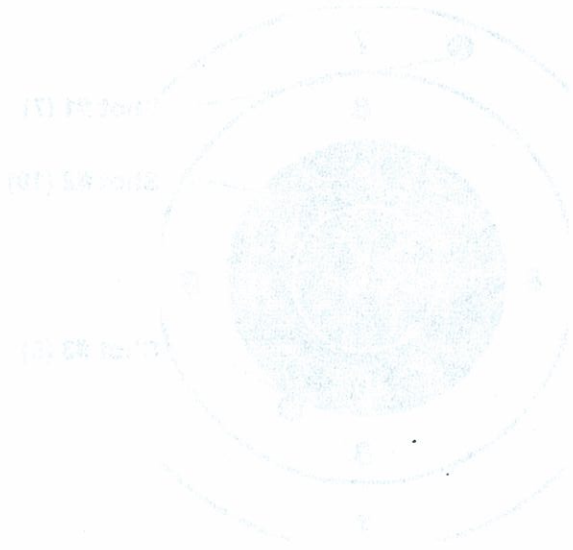

When a shooter's shot group is centered in the bullseye, it is possible to score your target.

The target is used to determine the number of points that you score. The number of points that you score is based on the number of points that you score. The number of points that you score is based on the number of points that you score.



## LESSON 7: THE PRONE POSITION

### PURPOSE

This lesson introduces you to the correct technique for firing in the prone position.



*prone  
sling*

### INTRODUCTION

The **prone** position has the lowest center of gravity and is the steadiest of the three target positions. Prone has extra stability because the shooter is allowed to use a **sling** in this position. A highly trained rifle shooter is capable of holding a rifle almost as steady in the prone position as a test cradle or machine rest can hold a rifle.

The 50-meter prone position world record is a perfect 600 out of 600 possible points. Firing at 50 meters is done with .22 caliber rimfire smallbore rifles on a target with a ten ring that is only 10.4 mm in diameter (A dime is 17.8 mm in diameter). Shooting a perfect world record score in the prone position means hitting a target that is over one-half of a football field away and less than 6/10ths the size of a dime 60 consecutive times. Even more astonishing is that six different shooters have fired perfect 600s eight different times in world record competitions.

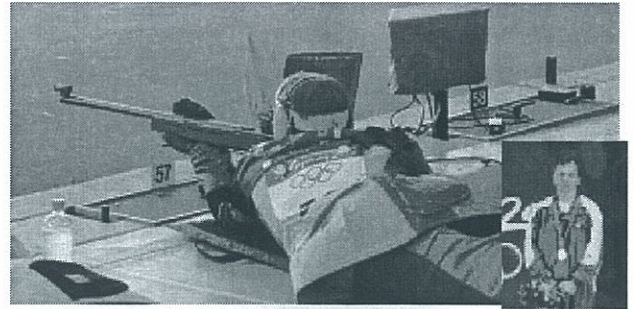

*Sergey Martinov from Belarus is one of six shooters who have fired perfect 600x600 world record scores. Martinov has fired three 600s in world record competition.*

### FEATURES OF SUCCESSFUL PRONE POSITIONS

The first step in learning any shooting position is to study the positions of successful shooters. The prone position photo below is the position used by world record holder Sergey Martinov. School-age shooters with sporter air rifles and clothing demonstrate their prone positions in the other photos.

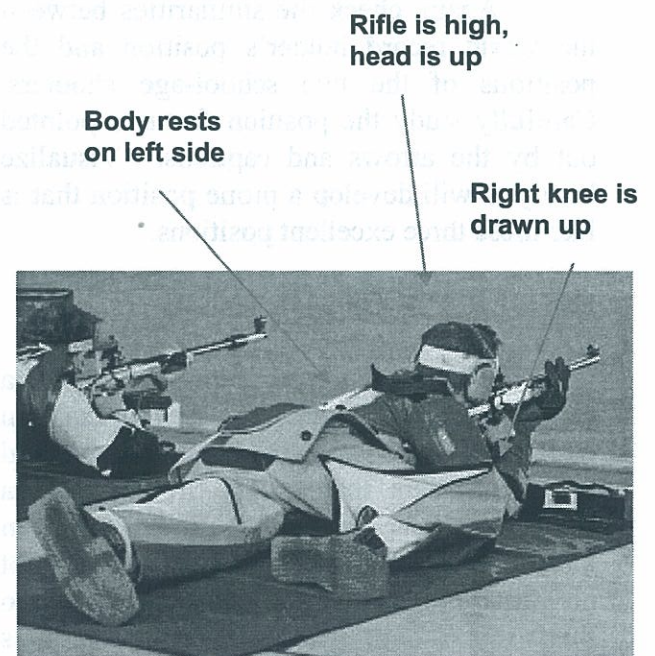

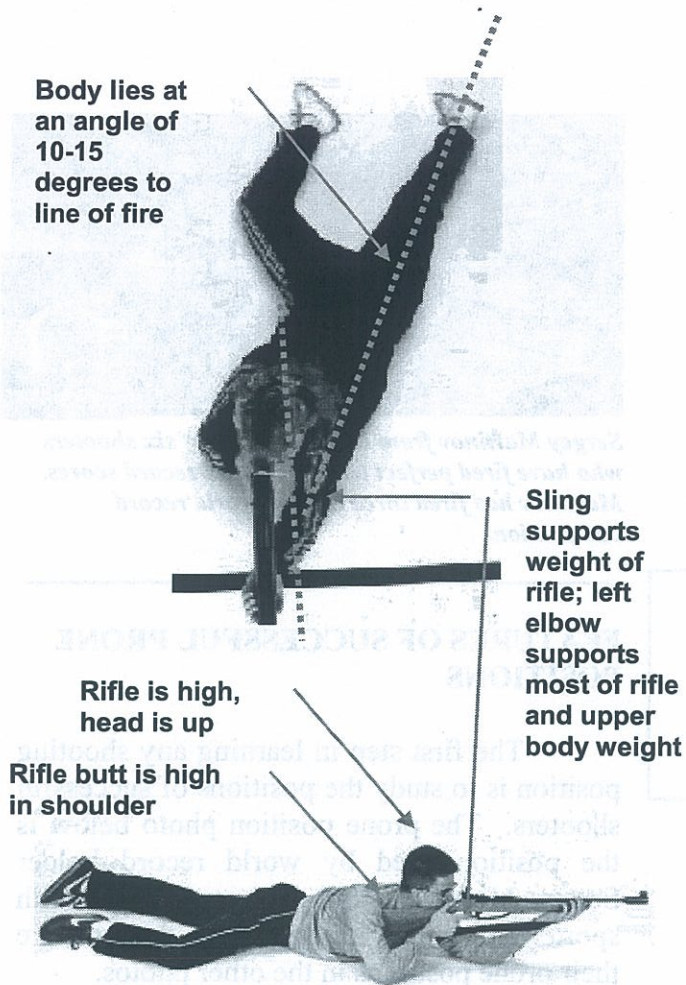

without a sling is a mistake. To learn the correct position and get the highest possible scores, a sling must be used in the prone position.

To take full advantage of the support that the sling provides, you need to understand how the sling is designed and used. The illustrations here show you how to place the sling on your arm so you will be ready to use it when you get into the prone position.

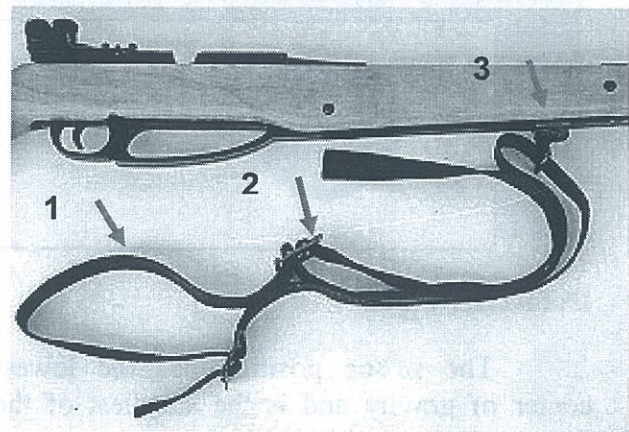

*All target shooting slings have similar features. They include 1) an arm loop with a means of tightening the loop around the arm, 2) a buckle or other means of adjusting the sling length and 3) a sling attachment point that can be adjusted forward and backward.*

Again, check the similarities between the world record holder's position and the positions of the two school-age shooters. Carefully study the position features pointed out by the arrows and captions. Visualize how you will develop a prone position that is like these three excellent positions.\*

### PROPER USE OF THE SLING

Competition rules allow the use of a **sling** in prone and kneeling. Scores that can be fired with the sling are so much higher and more consistent than scores fired without a sling that all successful shooters use slings in those two positions (the use of a sling is not permitted in standing). It may be tempting to think that shooting in the prone position is easier without a sling, but trying to shoot

**Step 1.**  
**Detach the sling from the rifle, form a loop for the arm**



**Step 2. Place sling loop high on arm, tighten sling loop around arm**



**Sling supports 100% of rifle weight**

*The remaining steps to attach and adjust the sling are described in the prone position instructions that follow. With a properly adjusted sling, the muscles of the arm can be completely relaxed.*

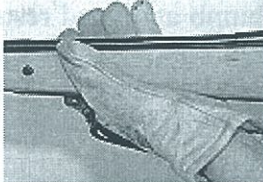

*Wearing a glove on the support hand makes using the sling more comfortable. If a shooting glove is not available, a normal leather work glove may be worn.*



*A large safety pin or other fastener may be used to keep the sling from slipping down on the arm.*

## LEARNING THE PRONE POSITION

A step-by-step process should always be used when learning a new shooting position. After studying the position and becoming aware of the importance of using the sling, it is time to move to the firing line and begin to develop your own prone position. Here are the steps to follow:

- 1. Study the Position.** Take another look at ideal prone position photos. Imagine placing your arms, body and legs in a similar position. Put the sling on your support (left) arm so that it will be ready when the time comes to attach it.

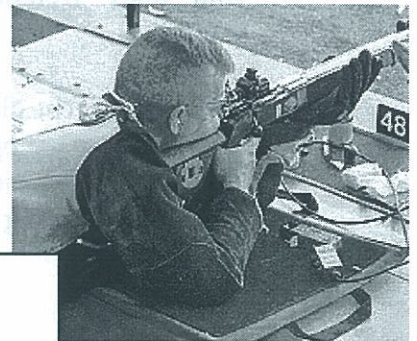

*Major Mike Anti, U. S. Army Marksmanship Unit, is shown firing in the prone position during the 2000 Olympic Games.*

*The photo on the left shows how the arms and sling support the rifle while keeping the butt high in the shoulder and the head up. The photo above demonstrates the angle that the body should lie in relation to the rifle. His right knee is drawn up to roll the body onto the left side. Note how erect his head is in both position views.*

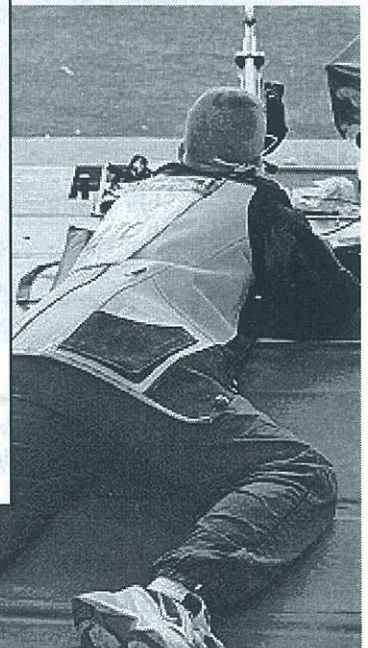

**2. Get into position without the rifle.**

Start by placing your air rifle on the floor next to the shooting mat. Then place your shooting mat at an angle of about 10 degrees to the line of fire.

- Stand at the rear of your shooting mats. Kneel and lie down on the mat, facing the target. Your body should lie at the same 10 degree angle to the line of fire as the mat.
- Extend your left arm to the front and place your left elbow on the mat.
- Bring your right knee up and roll your body weight onto the left side.
- Place your right elbow on the mat to also help support the upper body. Position both hands as if they are holding an imaginary rifle.



With right knee drawn up, more body weight is on the left side and left elbow

*2. Get into the prone position without the rifle. Support the upper body with the left elbow and brace the body in position with the right elbow. Imagine holding a rifle in this position.*

**3. Get into position with the rifle, but without the sling.** The next step is to pick up the rifle and hold it in

position.

- Place the butt plate high in your shoulder and close to the neck. The butt plate location is correct when your head is high enough that you can comfortably look straight forward to see your target.
- Hold the rifle with both hands. Make sure your elbows are positioned so they comfortably support the upper body and rifle. Most of your weight should be on the support elbow.
- While looking through the sights, move your support (left) hand forward and rearward on the fore end. This will determine where to locate the hand to raise the rifle to a point where the sights naturally point at the target.
- When the correct support hand position is determined, mark that point on the fore end where the V between the thumb and hand rests. The instructor or another cadet can also assist you by marking that point.



*3. Add the rifle to the position. Move the left hand forward and rearward on the fore end until the front sight is at the level of the target. Mark the location where the V between the thumb and hand is located.*

**4. Attach and adjust sling.**

- a) Attach the sling. Extend the sling and be sure it is adjusted so that its length reaches the extended finger tips of the left hand. Rotate the sling swivel one-half turn to the right (clockwise as you look at the sling swivel). Attach the sling to the sling attachment point (Daisy M853/753 rifles) or attach the sling swivel to the rail.

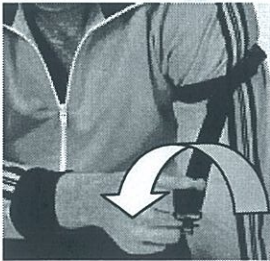

*4-a. Extend the sling and rotate the sling swivel one-half turn to the right (clockwise direction).*

- b) Get back into the same prone position you just had with the rifle and without the sling. This time the sling should be attached. The sling swivel should be forward of your hand and the sling should be loose. Wrap your arm around the sling so that the sling passes over the back of the hand and around the inside of the arm.

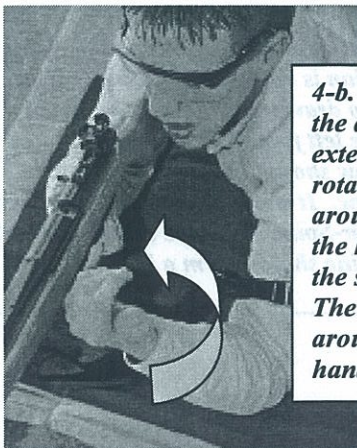

*4-b. To properly place the arm in the sling, extend the arm and then rotate it clockwise around the sling so that the hand rests between the sling and fore end. The sling should pass around the back of the hand.*

- c) Place your left hand in the same location that you marked previously. Check your position to be sure the rifle points comfortably at the center of your target. If the front sight rests above or below the target, move the left hand forward or rearward to get the sights on the target. Move the sling swivel to the location where the V between your thumb and hand is located and tighten it. The best way to do this is to have the assistance of an instructor or other cadet who can adjust the sling swivel by moving it back to the left hand position and tighten it in place.



*4-c. With the left hand in position, move the sling attachment point or sling swivel back to the hand and tighten it in place.*

- d) Complete the position by tightening the sling until it takes over the work of holding up the rifle. The sling should be tight enough so that no muscle effort by the arms is necessary to help hold up the rifle.



*4-d. Finish the sling adjustment by tightening the sling until the sling and not the left arm muscles, do the work of holding up the rifle.*

5. **Align the position.** After tightening the sling, one more step is necessary to be sure your prone position produces the smallest possible groups and highest scores. You must align your position with the target.

- Get into position and let the rifle point where it naturally wants to point, without trying to force the rifle to point at the target. A good way to do this is to close your eyes or look down while you relax your arms and upper body and let the sling support the rifle. Next, look through the sights to see where the rifle is pointing. If the sights are not aligned on the target, you need to align your position by moving your body.
- When aligning your body-sling-rifle system on the target, do not move the support (left) elbow. Use the support elbow as a fixed pivot point. If the rifle is too high or too low, use your feet to push the body forward slightly, to lower the rifle muzzle. Or use your feet to pull the body back slightly to raise the muzzle.
- If the rifle points to the left or right, use your feet to lift the body and gently shift it to the left or right to bring the rifle onto the target. Again, do not move the support elbow—always use it as the pivot point.
- Check position alignment again to be sure the sights now point naturally at the target. The prone and kneeling positions have a “natural point of aim” that must be aligned with the target.

Shift body left or right to make horizontal adjustment

Shift body forward or rearward to make vertical adjustments

Pivot Point, do not move left elbow

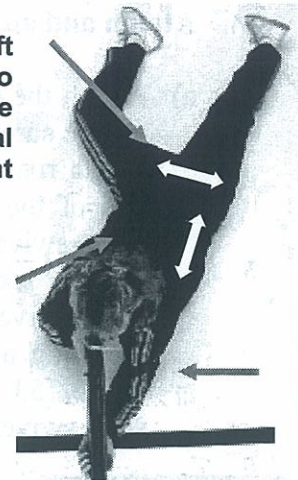

1) Left-side line

2) Shoulder-spine T

3) Elbow placement

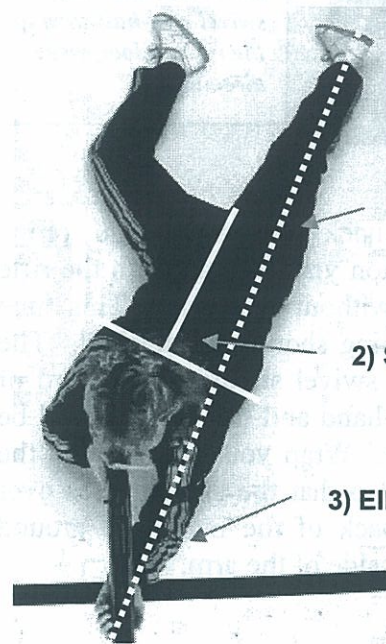

*As you prepare to fire, here are three things to check to be sure your position is correct. 1) Left-side line: You should be able to draw a straight line from the left hand through the left foot. 2) Left elbow placement: The elbow should be located directly under the left-side line. It should not be forced under the rifle. 3) Shoulder-Spine T: Lines drawn through the shoulders and spine should form a T.*

## PRONE POSITION FIRING

You should now be ready for dry and live firing in your new prone position. Your instructor will likely begin by doing several dry firing repetitions to practice aiming, breathing, centering your sight picture and smoothly pressing the trigger to release the shot without disturbing your aim.

To fire a series of shots in the prone position, it is also necessary to develop a successful technique for loading the air rifle in the prone position. Loading the air rifle in prone is more difficult than in standing. The method of loading that is used in the prone position depends on the type of air rifle that is used.

- Sporter air rifle, Daisy M853/753. With the pneumatic air rifle, it is necessary to take the rifle off the shoulder and then to take the hand out of the sling so that both hands are available to cock the rifle. The illustrations show two methods of cocking the pneumatic air rifle in the prone position
- Compressed air and CO2 rifles. Loading these rifles is simply a matter of dropping the rifle from the shoulder, opening the bolt, loading and pellet, closing the pellet and placing the rifle back in the shoulder for the next shot.

After your instructor gives the command **START** to begin firing in the prone position, think about relaxing your arms so that the sling does the work of holding the rifle. Center the bull's-eye in your front sight ring as perfectly as you can. You will still have some hold movement, so be sure to relax and center the movement within the front sight ring. When you have a good sight picture, smoothly squeeze the trigger until each shot fires. When you finish firing, be

sure to open the bolt on your rifle and wait for the instructor to inspect it.



*Method 1: Left elbow remains in place. Left hand comes out of sling and grasps cocking lever. Right hand pulls rifle to rear and then pushes it back forward to cock the rifle. The left hand is then repositioned in the sling and loading is completed by the right hand.*



*Method 2: Rifle is turned over and left hand holds rifle while right hand operates the cocking lever. The left hand is then repositioned in the sling and loading is completed by the right hand.*

## CONCLUSION

This lesson gives step-by-step directions for achieving the correct prone position. It also tells you how to use a sling. Firing accuracy in the prone and kneeling positions is greatly increased by using a sling.

## LESSON 8: THE KNEELING POSITION

### PURPOSE

This lesson introduces you to correct technique for firing from the kneeling position



*kneeling kneeling roll*

### INTRODUCTION

In the **kneeling** position, the shooter kneels to sit on the right foot that is supported by a **kneeling roll**. The rifle is supported by the sling and left arm that rests on the left leg. The kneeling position is similar to prone in that the sling is also used in this position. It is similar to standing because the body's center of gravity is higher and precise balance is essential to achieving a stable kneeling position.

In the kneeling position, one additional item of equipment is used, a kneeling roll. It is possible to shoot kneeling by sitting on the side of the right foot, but only a few shooters have ever been able to use that position successfully. All of the top kneeling shooters in the world today use a kneeling roll. Its use is highly recommended.

If your unit does not have kneeling rolls available, it is easy to make suitable kneeling rolls. Pieces of heavy fabric can be sewn to form a cylinder that is eight inches long and six inches in diameter. Fill the cylinder about 80% full with birdseed, wood chips or other similar material. A kneeling roll can also be made by cutting a eight inch wide strip of carpet and rolling it into a kneeling roll, that is about four or five inches in diameter. Kneeling rolls cannot be more than 10 inches long or 7.2 inches in diameter.



Sling

**Kneeling roll**

*A competitor in the 2000 Olympic Games firing in the kneeling position.*

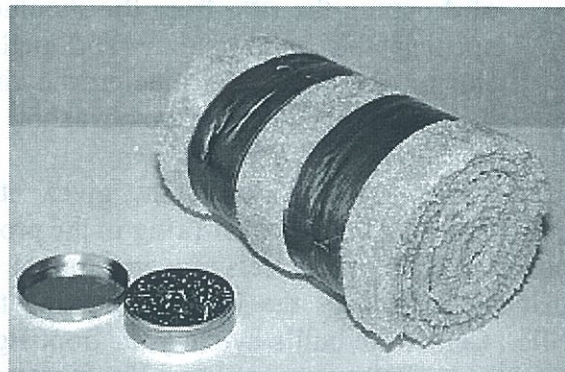

*A suitable kneeling roll may be made by rolling a strip of carpet to form a roll. Tape the roll to keep it rolled tightly.*



## FEATURES OF SUCCESSFUL KNEELING POSITIONS

Like the standing and prone positions, mastering the kneeling position also must begin by studying the positions of experienced, successful shooters. The first kneeling position photo below, shows Tatiana Goldobina of Russia firing during the 2000 Olympic Games. She won a silver medal in the women's 50-meter three-position rifle event. The second photo below, shows a school-age shooter with a sporter air rifle. The arrows on both photos point out the key features to study and copy when you begin to shoot in the kneeling position.

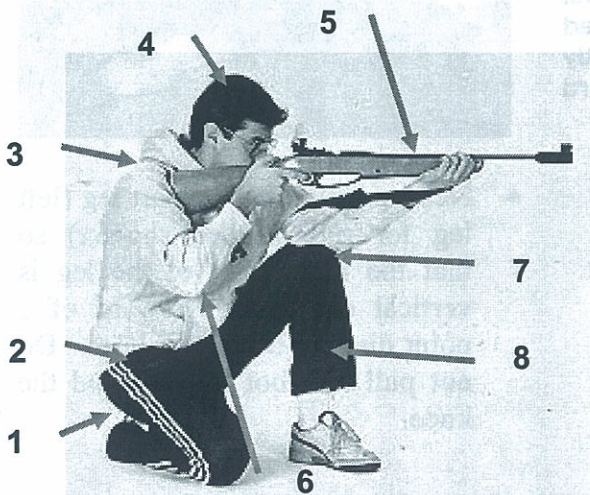
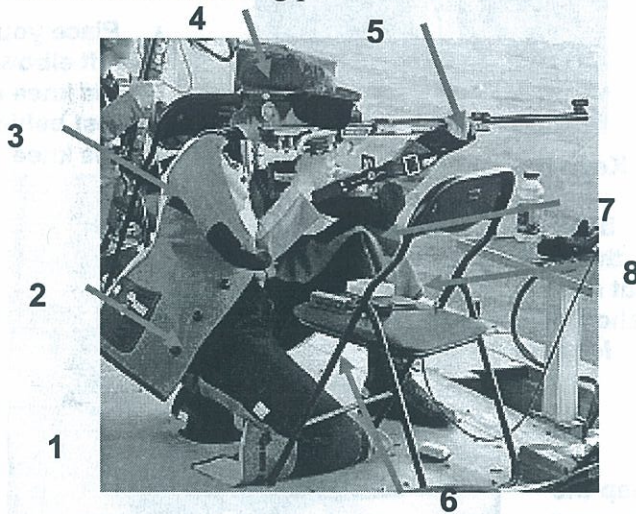

Kneeling position features that are marked with arrows are:

1. Foot is placed on a kneeling roll. The kneeling roll allows the shooter to comfortably sit on the foot for long periods.
2. Almost all of the weight of the shooter's body rests on the heel.
3. The torso is fairly erect, but the shoulders are rolled forward. The shoulders are not erect, but instead are rolled forward or slumped down.
4. The head is fairly erect. It is tipped toward the target, but not to the right.
5. The support hand (left hand) location is far enough back on the fore end to place the rifle fairly high in the shoulder and keep the head erect. The sling supports the weight of the rifle.
6. The body is turned 30-45 degrees away from the target.
7. The elbow of the support (left) arm is located on top of the knee. Other successful shooters place the left elbow just behind the knee. The elbow must not be more than 6 inches behind the point of the knee or 4 inches in front of the point of the knee.
8. The left lower leg that supports the rifle (left leg) is vertical. Some shooters move the left foot farther forward so that the foot is slightly in front of a point directly below the knee. The foot is never pulled back so that it is behind this point.

15 minutes while you study or watch TV.

## LEARNING THE KNEELING POSITION

The step-by-step process for developing a kneeling position is almost identical with the steps that are followed in learning the prone position. Working out a position first without the rifle and then with the rifle, but without the sling, are especially important in kneeling. These steps help you establish the correct relationships between the different parts of your body. Do not skip these steps.

1. **Study the position.** Take the time to go through each of the eight points identified in the position illustrations. Visualize how you will place your body in a similar position.
2. **Kneeling position without rifle.** Begin by placing your kneeling roll on your firing point. Turn it so that it points between 30 and 45 degrees away from the target. After you practice the kneeling position for several days, you can adjust this angle so that it is most comfortable for you.
  - Next, kneel down and place the front part of your ankle over the kneeling roll. Then sit on your right heel.
  - Sit back on your heel so that as much of your body weight as possible rests on the heel.
  - Do not be discouraged if it is uncomfortable at first to sit on a kneeling roll with all of your body weight resting on your heel. If you have problems with this, try improvising a kneeling roll at home so you can practice sitting in this position for periods of ten to



Keep the foot vertical and sit with your weight on the heel

*To start building the kneeling position, place the kneeling roll on the floor and turn it 30-45° from the target. Place your ankle on top of the kneeling roll and sit on your heel.*

Keep the weight back on the heel, but roll the shoulders forward

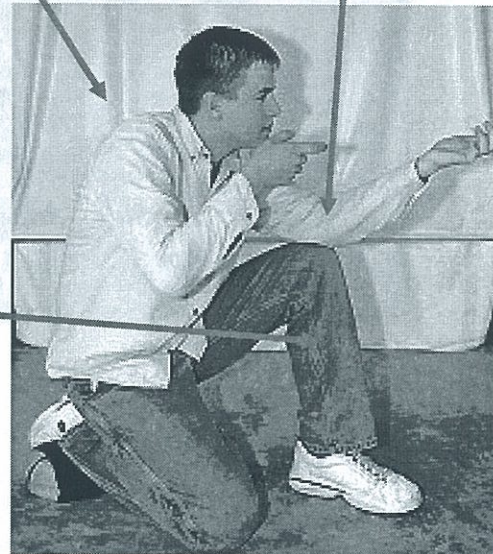

Place your left elbow on the knee or just behind the knee

Keep the left lower leg vertical or angled slightly forward

- Next, position the support leg (left leg for right-handed shooter) so that the lower part of the leg is vertical or slightly forward of a point directly below the knee. Do not pull the foot back behind the knee.

- With the body weight on the heel, let the shoulders slump down or roll forward. You should keep your weight back on your heel, but do not try to sit up straight in kneeling.
- Lift the support (left) arm and hold it above the knee. Then simply drop the elbow onto the knee or leg. Depending upon how your body is built, your support elbow may fall on the knee or it may fall on the upper leg just above the knee.
- Complete the kneeling position without the rifle by lifting the right arm to hold an imaginary rifle. Think about how your body feels in this position. Try to relax your body and balance your body weight over your heel.

**3. Kneeling position with rifle, without sling.** The next step is to pick up the rifle and hold it in position. Pay close attention to finding the correct position for the butt plate in the shoulder and for the left hand on the fore end.

- Position the butt plate in the shoulder, close to the neck, and high enough that your head is fairly erect.
- Move the support (left) hand forward and rearward on the fore end to find the hand location where the sights are raised to the level of the target. When the correct hand location is identified, mark the point where the V between the thumb and hand lies on the fore end.

Place butt high enough in shoulder to keep head erect.



Shift left hand forward and rearward until sights are at target height. Move the sling swivel back to the hand and tighten



Move the sling swivel back to the left hand.

Then tighten the sling until it fully supports the weight of the rifle.

**4. Kneeling position with rifle and sling.** All that remains is to complete the position by adjusting the sling swivel and tightening the sling.

- To start this step, place the sling loop on the arm. Tighten the sling loop so that it does not slip down on your arm. Adjust the sling so that it is much too long and position the sling swivel far out on the fore end.

- Replace the rifle in position on the shoulder with the sling on. At this point, the sling should still be adjusted so that it is too loose or long.
- Return the left hand to the location marked on the fore end. Move the sling swivel back to the hand and tighten it.
- Complete the position by tightening the sling until it fully supports the weight of the rifle.
- Check the alignment of the position on the target. If your natural point of aim is left or right of the target, align the position by rotating the entire position (left foot and right knee) on the kneeling roll. If the rifle points above or below the target, it is necessary to move the left hand back to raise the rifle or forward to lower the rifle. The sling and sling swivel will have to be readjusted as part of this change.

## KNEELING POSITION FIRING

You will probably begin your firing exercises in kneeling by dry firing. Use your dry fire repetitions to work out the shot technique that you will use in kneeling. Try to follow these steps as you dry fire each shot.

- Close the bolt, place the butt in your shoulder, and align the sights on the target.
- Breathe naturally, exhale, and stop breathing—let the left arm relax so that only the sling holds up the rifle.
- Take up the trigger slack and add some pressure to the trigger.

- Center your hold movement (sight picture) and add more pressure to the trigger until the shot releases

*When firing in the kneeling position, keep the weight of the body and rifle balanced over the heel. The balance line on this kneeling illustration shows how the weight of the body and rifle are to be balanced over the right heel. The shooter is Raimond Debevec, Slovenia, 2000 Olympic gold medal winner in men's 50 meter three position rifle.*



*To cock and load the M853/753 pneumatic air rifles in kneeling, take the rifle from the shoulder and the hand out of the sling. Work the cocking lever, replace the left hand in the sling, load the pellet and replace the butt in the shoulder.*

## CONCLUSION

As you make dry and live fire shots in kneeling position, think about your position to be sure 1) your body weight is resting on your heel, 2) your left lower leg is vertical, 3) your left elbow rests on your left knee or upper leg just above the knee and 4) your sling is tight enough to fully support the weight of the rifle.



## LESSON 9: PRACTICE AND SKILL DEVELOPMENT

### PURPOSE

This lesson will help you understand how marksmanship skill is developed through study, analysis, and practice.



*development  
practice  
shot plan  
skills*

### INTRODUCTION

In previous lessons you learned the basic elements of target rifle shooting. These basics included safety; equipment; the standing, prone, and kneeling positions; the technique of firing shots; sight adjustment; and scoring. This lesson shows you how to put all those basics together so that you can play a complete game or, as it is called in shooting, fire a complete course of fire.

This lesson also begins to teach you some important ways to become a better shooter. When you reach the point where you can fire a complete course of fire, you are also ready to learn how to improve your shooting. The most effective ways to improve target rifle scores that will be covered in this chapter are **practice**, keeping a shooting diary, using a **shot plan**, and learning to relax and balance your position before each shot.

### TARGET RIFLE RULES

The most common three-position air rifle competition event for JROTC and high school rifle teams is the 3x10 event. 3x10 means firing ten record shots in each of the three positions, prone, standing and kneeling. JROTC rifle team members also sometimes fire 3x20 events (20 shots in each position) in major competitions. The 3x10 and 3x20 events are sometimes also called courses of fire.

The standard instructional technique for teaching every complex sport is to break the game down into different individual **skills** and then to teach those separate skills one at a time. A golfer learns stance, grip and various stages of the swing before putting it all together. The same approach is used in shooting. Completing a 3x10 shooting event means putting everything you have learned so far together, to play a complete game of target rifle shooting.

When you are ready to play a complete game in any sport, there are special rules for that sport. Sport rules provide order and consistency for competitions and ensure fair play among all participants. The rules that govern three-position air rifle shooting are called the *National Standard Three-Position Air Rifle Rules*. A National Three-Position Air Rifle Council establishes these rules. The Council includes representatives of almost all major shooting sports organizations and the military cadet commands (Army, Navy and Marine Corps JROTC).

This rulebook is often called the “Blue Book.” A copy of the National Standard Rules should be available at your JROTC unit. If a copy is not available there or if you want to print out a copy of your own, check the Civilian Marksmanship Program Web site at <http://www.odcmp.com/3P/Rules.pdf>.

A complete copy of the National Standard Rules is posted at that Web site.

In competitions, the 3x10 event has a specific order for the positions to be fired as well as time limits for preparation before the event, for each of the positions, and for changing from one position to the next. The chart shows how this event is conducted.

Individual 3x10 Event	Time Limit
Preparation period	10 minutes
10 shots prone	20 minutes
Change-over period	5 minutes
10 shots standing	20 minutes
Change-over period	5 minutes
10 shots kneeling	15 minutes

When you fire a shooting event according to competition rules, there are some rules you will especially need to know.

- Time Limits.** In competitions, there are time limits for each position. In the 3x10 event, competitors have 20 minutes to fire 10 shots prone, 20 minutes for 10 shots standing, and 15 minutes for 10 shots kneeling. The time limit includes the time for practice or sighting shots that must be fired before the 10 record shots for each position. No shots may be fired after a time limit expires.
- Preparation Period.** Shooters must be given ten minutes before the start of the first position, prone, to set up their equipment, and prepare to fire. Shooters should get into position during this period and dry fire to prepare for shooting. Dry firing is permitted during preparation periods. However, it is not permitted to charge air rifles with gas, discharge gas or load and fire a shot during preparation periods.

- Changeover Periods.** Shooters are given five minutes between positions to change their equipment and prepare for the next position. Shooters may get into the next position and dry fire during the changeover period.
- Team Events.** Teams normally consist of four shooters. Team members must be named before the competition starts. Team scores are calculated by adding the individual scores of the four team members.
- Sighters and Record Shots.** The targets that each shooter fires at are designated as either sighter or record targets. Shots fired on sighter targets are for practice. Most shooters fire several sighting shots before they start for record, to determine whether sight adjustments are necessary. Sighting shots also serve as warm-up shots. Every shot fired on a record target counts in the shooter's score. Once a shooter begins to fire record shots it is not permitted to return to the sighter or practice target.

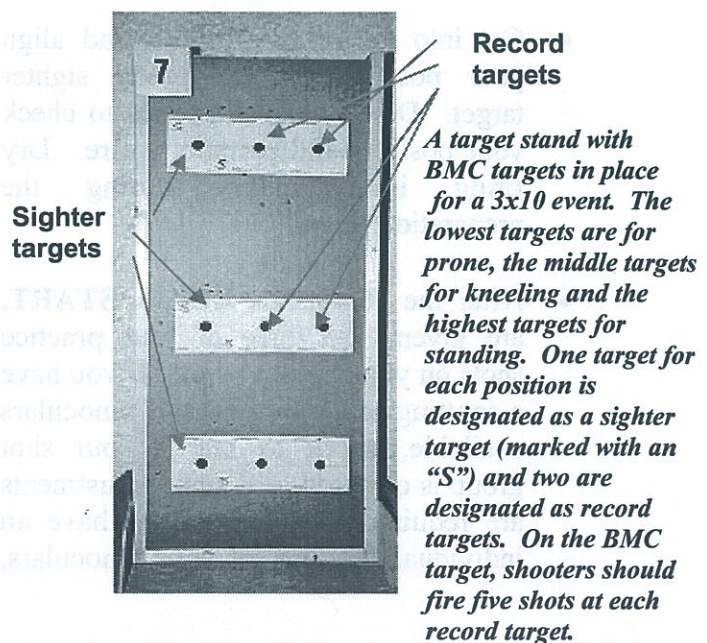



*The 3x10 course of fire begins with firing sighters and 10 record shots in the prone position. It continues with firing in the standing and kneeling positions.*

The first time you fire a 3x10 course of fire will probably be in a practice setting where the instructor will not enforce time limits. By the end of the marksmanship course, however, you should have an opportunity to fire a 3x10 event where official time limits are enforced. When you do this, the procedure you follow should include these steps.

- After the instructor or range officer calls you to the firing line and starts the preparation period or gives instructions to get ready, lay out your shooting mat and rifle and prepare to fire in the prone position. You may remove the CBI from your air rifle during the preparation period. You also you may dry fire, but not discharge air or load.
- Get into the prone position and align your position on the prone sighter target. Dry fire several times to check your position and prepare to fire. Dry firing is permitted during the preparation period.
- After the commands **LOAD, START**, are given, fire three or four practice shots on your sighter target. If you have a spotting scope or a pair of binoculars available, check to see if your shot group is centered or if sight adjustments are required. If you do not have an individual spotting scope or binoculars,

your instructor may have one. Coaching assistance is permitted during sighting shots in most competitions. The instructor or coach can check the sighting targets of the shooters on the firing line to advise if sight adjustments are needed.

- After firing few sighting shots to be sure your rifle is zeroed, “go for record” by shifting to your first record target. You may need to move your whole body slightly to be sure your natural point of aim is aligned on the new target. Fire five shots on each record target. Shift your position to the second record target and fire five shots on it.
- When you finish 10 record shots in the prone position, open your rifle action and lay it on the mat. Be sure to insert the CBI in your air rifle barrel. You may get out of position and move to the rear of the firing line.
- When all cadets complete ten record shots in the prone position, you will be instructed to change targets and prepare for firing in the standing position.
- After the commands **LOAD, START**, are given, you should again fire a few sighting shots and five record shots in each target from the standing position.
- The process of changing from standing to the kneeling position is the same as it was from prone to standing. After you are in kneeling, the commands **LOAD, START**, will be given for you to begin firing in this position.
- After all 30 record shots are fired, you will have an opportunity to score your targets and post scores on a chart or score sheet.



## PRACTICE -THE KEY TO IMPROVEMENT

Shooting is a skill sport where natural ability has little to do with ultimate success. Fortunately in shooting, how much a person practices, is the most important determinant in how well that person does. Shooting is also a sport where your first scores on targets are not a good way to predict how well you will ultimately do. The best way to predict how well someone will do in shooting, is how much they are willing to practice. A shooter with the motivation to practice and work hard will almost always do well.



*Two JROTC rifle team members in a practice session. They are using precision air rifles and shooting jackets that are permitted in many school competitions. Practices should be as frequent as possible and stress work in the standing and kneeling positions.*

If you want to improve in rifle shooting, take advantage of the practice opportunities that your instructor makes available to you. When you have a chance to practice, spend as much time on the firing line actually shooting as you can. There are some important training principles that also will make your practices more productive.

- **Frequency.** The more times each week that you can practice, the better you will become.
- **Difficulty.** Spend more time on the most difficult positions, standing and kneeling.
- **Problem Solving.** When you are having a special problem with some phase of your shooting, spend extra time trying to solve the problem. Ask your instructor to help you find books or other resources that will give you information about how to solve the problem.
- **Goals.** Set short-term goals for your practice. For example, you may set a goal of shooting all of your shots inside the 8 ring on the BMC target or making a smooth trigger release on all your shots in a 3x10 course or having the left arm completely relaxed on every shot. Goals can also be focused on scores or averages if they are realistic and attainable.

## KEEPING A SHOOTING DIARY

One of the best ways to advance in target shooting is to keep a Shooting Diary. The diary is a written record of all practice and competition firing. Keeping a diary gives you an opportunity to write down things that you learn or to identify problems that you need to solve in future practices. A diary is one of the best ways to analyze your shooting so that you can reinforce what you are doing right and correct what you are doing wrong.

Date		Location		Rifle/Ammunition:	Training/Competition
Scores-Prone	Scores-Standing	Scores-Kneeling	Totals	Sight Changes	
				KN to PR +/- _____ L/R _____	
				PR to ST +/- _____ L/R _____	
				ST to KN +/- _____ L/R _____	
What I Learned					
Problems to Solve					
Date		Location		Rifle/Ammunition:	Training/Competition
<i>15 October 01</i>		<i>School Range</i>		<i>Daisy 853, reg. pellets</i>	<i>Practice</i>
Scores-Prone	Scores-Standing	Scores-Kneeling	Totals	Sight Changes	
<i>92</i>	<i>78, 86, 83</i>	<i>91,86</i>	<i>Practice</i>	KN to PR +/- <u><i>+4</i></u> L/R	
				<u><i>L2</i></u>	
				PR to ST +/- <u><i>-2</i></u> L/R	
				<u><i>R3</i></u>	
				ST to KN +/- <u><i>-2</i></u> L/R	
				<u><i>L1</i></u>	
What I Learned					
<i>My standing scores got a lot better after my first ten shots when I started checking my balance before each shot.</i>					
<i>My first kneeling was very good for me—I concentrated on keeping the bull inside the front ring—I stopped paying attention to that on my second 10 and my score went down.</i>					
Problems to Solve					
<i>In prone, when I get back into position after loading I am not getting my left arm relaxed—I have to learn to do that.</i>					
<i>In kneeling, I do much better when I really concentrate on my sight picture—I must do that on every kneeling shot.</i>					
<i>I still have quite a bit of body movement in standing—I think I can stop some of that by checking my balance before every shot.</i>					

*This is a Shooting Diary page with one part left blank and one part filled out, to show how information is kept in a Shooting Diary.*

Shooting Diary pages can be easily created in most word processing programs. Entries in your Shooting Diary should include:

- Data about the firing activity including date, rifle and pellets used, etc.
- Scores you fire in each position.
- Sight changes you make (or should have made) when you fire in each position (+/- means clicks up or down, L/R means clicks left or right).
- Write down at least one thing you learned or did well during your firing exercise.
- Write down at least one problem you encountered that you would like to correct the next time you practice.

### DEVELOPING A SHOT PLAN

One of the keys to marksmanship success is consistency. Consistency is doing exactly the same thing at the same time each time you fire a shot. The best way to **develop** consistency is to have a “**shot plan**.” The shot plan is simply a step-by-step outline of the different things that you do to fire a shot. Using the same techniques each time you fire a shot is so important in learning target skills, that even beginner shooters should have a shot plan.

It is easy to prepare a plan. Think about each step that you follow when firing a shot, from loading the rifle, to placing it in position, to the details of your shot technique. Decide how you do each of those steps. Write that action down in your plan.

Once you have a shot plan, it is important to follow your plan on every shot you fire. The more closely you follow your plan, the more effective the plan will be in helping you develop consistency that leads to improved scores.



*Developing a personal shot plan means starting with how you load the rifle and then determining exactly how you perform each step in sequence in firing a shot. Shot plans work wonders when they are followed for each shot fired.*

<b>PERSONAL SHOT PLAN</b>	
SHOT PLAN STEP	DESCRIPTION OF HOW THIS STEP IS DONE
Loading	<i>Use left hand to open and close cocking lever. Use right hand to take pellet from pocket, load and close bolt.</i>
Placing rifle in position	<i>Lift rifle to shoulder, put butt plate on arm-shoulder joint. Hold rifle with right hand, form fist with left hand, put fist under cocking handle, get left elbow under rifle and drop arm and rifle onto side.</i>
Align rifle with target	<i>Start with front sight above target and lower rifle down to bull's-eye.</i>
Pre-shot checks	<i>Check to be sure left arm relaxes and is directly under rifle. Check balance—weight should be evenly spread on both feet.</i>
Breathing	<i>After checks, take two more breaths, let it out and hold.</i>
Aiming	<i>As soon as I start to hold my breath, try to center the bull's-eye in the front ring.</i>
Starting to squeeze trigger	<i>Take up the trigger slack when I start to aim. Put about half of the pressure on the trigger immediately.</i>
Hold control	<i>Concentrate on the sight picture, try to hold the bull inside the front sight ring as much as possible.</i>
Completing trigger squeeze	<i>When the sight picture is centered, add another step of pressure to the trigger. When it is centered again, add another step. The shot should go after two or three steps.</i>

*The “Personal Shot Plan”, illustrated here, demonstrates a shot plan for a beginner shooter who uses pneumatic air rifle and sporter class equipment. Normally a separate plan is prepared for each shooting position. (This plan is for the standing position.)*

The key to having an effective shot plan is identifying how you complete each of the steps listed. By writing them down you have a plan that you can follow for each shot that you fire. There is no perfect shot plan for every shooter. Each shooter will have different ways of doing each of these steps. It is not as important that you do something a certain way as it is to have a plan that assures that you do it your way every time you fire a shot.

### PRE-SHOT ROUTINE

To consistently fire accurate shots, one additional action is necessary. To do your best on every shot, you also must learn to properly prepare for each shot so that your body performs its very best in holding the rifle steady. For your body to hold the rifle as steady and well controlled as possible, it must be:

1. **Balanced**, with the body-rifle system centered as perfectly as possible over the support points for the position.
2. **Relaxed**, with only the minimum muscle tension necessary to hold the rifle being used.

The best way to assure that your body is relaxed and balanced when you fire each shot, is to perform a simple pre-shot check before each shot. This should be done after the rifle is placed in position and before you start to aim at the target.

You may have noticed that in the Personal Shot Plan chart you just looked at, that there was a blank for "pre-shot checks." To make a pre-shot check, just take a few extra seconds after aligning the rifle with the target to complete these steps.

1. As you bring the rifle down to the target, pause **BEFORE** beginning to aim. The illustrations at the end of this lesson show how two champion shooters who competed in the 2000 Olympic Games, pause to make pre-shot checks before they start to aim.
2. The first check should be for **balance**. In the standing position, take a few seconds to think about how the weight of the body and rifle is distributed on the feet. The weight should be balanced equally between the feet (left-right balance) and between the balls and heels of the feet (forward-rearward balance). In the kneeling position, the weight of the body and rifle should be balanced above the right heel on the kneeling roll and the left heel that supports the weight of the arm and rifle.
3. The second check is to make sure the body is **relaxed**. Do this by taking two or three breaths. Each time you exhale, let the muscles in your body relax or let go, especially the muscles in your support (left) arm. Do not start to aim and fire the shot until you feel calm and relaxed.
4. When your shot plan is written out, it should identify how you check your balance and relaxation before you start to aim and fire.

### CONCLUSION

This lesson has prepared you to fire a 3x10 event. Now you know how to play a complete game of three-position air rifle target shooting. This lesson also provided your first insights into how to improve your skills and scores as a target shooter. If you remain active in target shooting, you will discover that the challenge of becoming a better target shooter is a quest that takes many years of training, where you continually discover new ways to improve. Attaining excellence in all sports requires that kind of effort, but it is especially important in shooting.

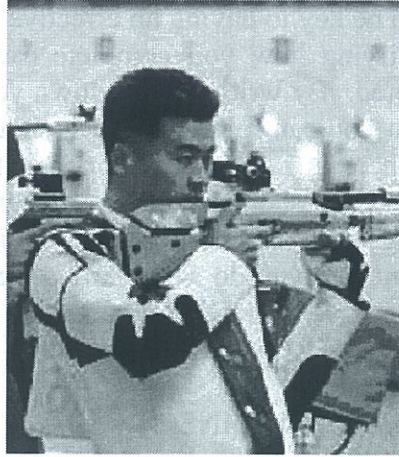

## LESSON 10: COMPETITION OPPORTUNITIES

### PURPOSE

This lesson teaches how to complete a competition course of fire and introduces cadets to the excitement and challenge of competition shooting.



*competition  
final  
self control*

### INTRODUCTION

Many cadets take rifle marksmanship instruction to learn about another sport and how to practice it. Many others take rifle marksmanship because they are interested in **competition** target shooting. Trying to become a member of the school rifle team is challenging and exciting to many cadets. This **final** lesson in the *JROTC Rifle Marksmanship Student Text* is for those who want to “go for it” and try competition shooting. It informs you about opportunities that are available to you in the sport of target rifle shooting.

This chapter first introduces the official competition target that is used in JROTC, school and other three-position air rifle competitions, as well as in all major air rifle competitions around the world. You will learn about finals that now conclude most major target competitions, from important junior competitions to the Olympic Games. The lesson ends with a review of the different

competition activities that you can participate in, as a member of a JROTC rifle team.

### THE COMPETITION EVENT

One big change between the 3x10 practice events that you have fired on the BMC target and regular 3x10 competition events, is the target. The official competition target has a tiny dot for a ten ring and all of its scoring rings from the 1-ring to the 10-ring are slightly smaller than the eight ring on the BMC target.

If you learned and practiced the basics of rifle marksmanship taught in the JROTC rifle marksmanship course, you are probably ready, or with a little more practice soon will be ready, to graduate from the BMC target to the official competition target. If you are able to keep your shots inside the 8-ring on the BMC target, you will now be able to keep your shots inside the scoring rings on the more difficult official target.

When firing a 3x10 or 3x20 competition event on the new target, there also is a difference in how the targets are configured. The competition targets are printed so that there are two sighting targets and ten record targets on one target card. Even after a few months of practice, shooters' skills become good enough that when five shots are fired on one target, the shots often are so close together, it is not possible to score them accurately. For this reason, competition shooters fire only one record shot on each competition target.

Many basic marksmanship courses end with everyone shooting a 3x10 course of fire on these competition targets. Cadets who join the rifle team will do all of their practice and competition on this target.

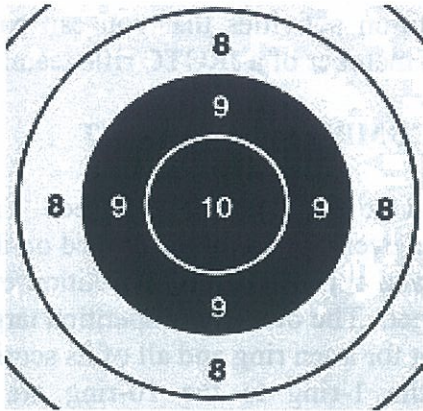

*The 8-9-10 rings of the BMC target.*

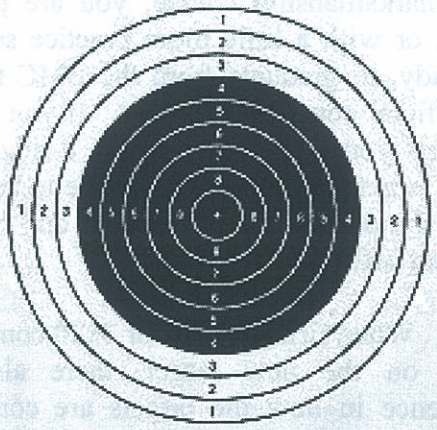

*The official 10 m air rifle competition target. The 10-ring is a 0.5 mm dot and the one ring is 45.0 mm in diameter.*



*Sporter air rifle finalists in the Junior Olympic National Championship prepare to fire one of their final round shots. The top eight shooters advance to the final. Finalists fire ten additional shots together, one-shot-at-a-time. Final round scores are added to the shooters' scores in the regular competition.*

## FINALS

If you become a rifle team member and your team attends major three-position competitions, you will probably go to an event where a **final** is fired. Even if you do not go to a competition with a final, the final system can be used for shooting games on your home range that are really fun. Finals are a relatively new and very exciting way to conclude target shooting competitions. Here are some important facts about finals.

- Shooting finals were first used in the 1988 Olympic Games. Finals are now used in almost all important target shooting competitions, including many competitions for high school teams.
- To advance to a final, a competitor must complete the first round of a competition and finish in the top eight. The eight shooters with the highest 3x20 scores qualify for the final. In some competitions, all shooters may be invited to shoot the final.
- In three-position events, the final is always fired in the standing position. All eight shooters in a final, shoot together on adjacent firing points. The shooter who finishes the first round in first place takes the number one position on the left. The shooter in eighth place takes the number eight position on the right.
- Finals start with a three-minute preparation period. A seven-minute sighting (practice and warm-up) period follows. Then finalists fire 10 shots for record, one-shot-at-a-time.



- To start each final round shot, the range officer uses the commands: FOR YOUR NEXT SHOT, LOAD, (pause), ATTENTION—3-2-1-START. Finalists have 75 seconds to fire one shot.
- After all eight finalists fire one shot, scores for that shot are announced. When electronic targets or special scoring equipment are available, final round shots are scored in tenth-ring values. A perfect center ten counts 10.9 points, while a ten that just touches the 10 dot scores 10.0 points. The range officer announces the eight shooters' scores after each shot ("Shooter one, 10.2; Shooter two, 8.7; Shooter three, 9.9; etc.").
- In many smaller competitions where special scoring equipment is not available, finals are still held, but scoring is done in whole numbers. When paper targets are used, the range officer can use a telescope to estimate and announce the shot values ("Shooter one, 9; Shooter two, 7, Shooter three, 10, etc."). The targets can then be "officially" scored immediately after the ten shots are completed so that final results can be announced.
- Spectators are encouraged to watch finals. Cheering before and after each shot is common and encouraged. At the 2000 Olympic Games in Sydney, there were 2,500 spectators in a grandstand behind the finalists. In addition, a live television signal of the shooting finals was broadcast to as many as two billion people around the world.

- Each finalist's final score is the total of the first round (3x10 or 3x20 shots) plus the final round score.
- Final scores are counted in individual rankings. Final scores are not counted in team scores or rankings.



*Men's air rifle finalists at a 2000 Pre-Olympic test competition in Sydney. The targets on this range are electronic. Note the scoreboards and monitors above each shooter and the electronic scoreboard on the left.*

## COMPETITION OPPORTUNITIES FOR JROTC RIFLE TEAMS

Cadets who are interested in target rifle shooting as a sport and who become members of their JROTC or school rifle team have many special competition opportunities. Competitions are a great way to measure your skills and progress as a shooter. They are always exciting, challenging experiences where you learn to control yourself and do your very best under pressure. They also offer opportunities to travel and meet new friends. Competition opportunities available to you include:

- **JROTC or School Rifle Team.** If your school has a JROTC rifle team or the school rifle team, your instructor will provide information about that program. Team members have a chance to practice regularly during the rifle season and to participate in competitions scheduled for the team.





*The winning teams in the 2000 National Junior Olympic Three-Position Air Rifle Championship. The top three teams were all high school JROTC teams from Hawaii, California and Georgia.*

- National Recognition Opportunities.** When school age rifle teams participate in major competitions, they become eligible to earn many special awards. Some of the most important awards are the Junior EIC badges and Distinguished Badges that are offered by the National Three-Position Air Rifle Council. Individual shooters who participate in Junior Olympic State and National Three-Position Air Rifle Championships can earn credit points for EIC badges and the prestigious Junior Distinguished Badge that are shown here. Distinguished Badges usually are awarded in special ceremonies.

There also are National Records for three-position air rifle shooting, including separate record categories for Army, Navy, and Marine Corps JROTC competitors. Check this Web site for information about the EIC and Junior Distinguished Badge program or to see the list of current national records: <http://www.odcmp.com/3P/Records.htm>.

The most comprehensive summary of all of the competition opportunities available in target shooting appears in the *Youth Shooting Opportunities Guide* that is published by the CMP. If your unit does not have a copy, the guide may be downloaded and printed from the CMP Web site at: <http://www.odcmp.com/Forms/ysog2002.pdf>.

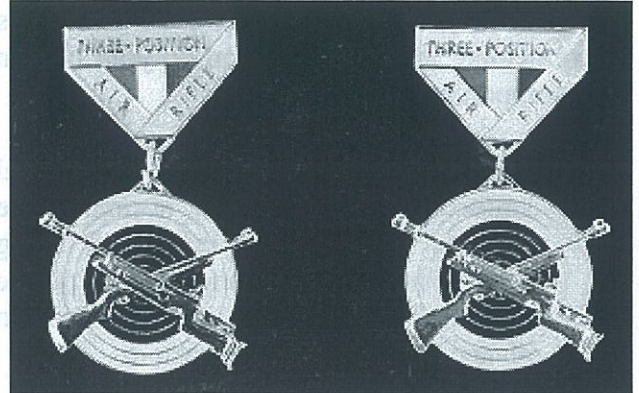

*Junior bronze and silver EIC badges*

*The prestigious Junior Distinguished Badge. The badge is awarded when a school age competitor earns 30 points in designated competitions.*

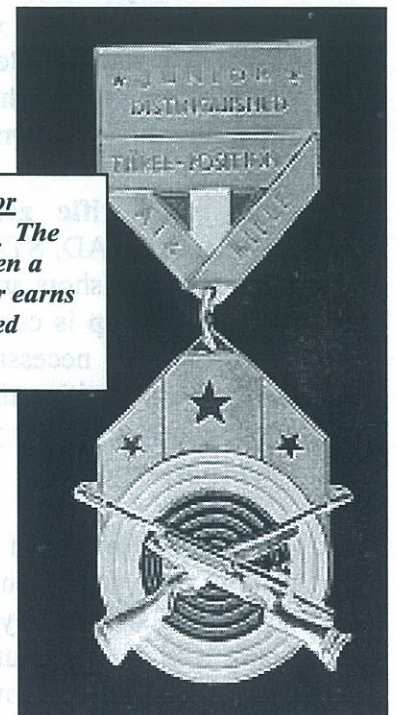

## TIPS FOR SUCCESSFUL COMPETITION OPPORTUNITIES

Most basic marksmanship instruction concludes with class participants firing a 3x10 event on the official air rifle targets under competition conditions (time limits, etc.). If you have a chance to fire a practice competition like that or if you go on to compete as a member of your rifle team, here are a few tips to remember that will help you do your best in the competition.

- **Firing point assignments.** In formal competitions, you will normally be assigned to a specific relay and firing point. Find out when and where you are scheduled to fire and be there well in advance so you can be prepared.
- **Be ready!** When the instructor or range officer calls you to the firing line for each position, set up your equipment and get into that position. Be sure to align the position on your sighter target and dry fire a few shots to warm up.
- **Keep your rifle zeroed.** After the commands LOAD, START are given, fire a few sighting shots and check to be sure your shot group is centered. Make sight adjustments if necessary. At any time during a competition that your shot group is not centered, adjust your sights to keep your rifle zeroed.
- **Remember your shot plan.** Consciously follow your shot plan for each sighting and record shots that you fire. If you are doing well, do not count up your possible score—just keep following the shot plan for each succeeding shot. If you have a poor shot, forget about it and remind yourself to just follow your shot plan to try to fire a good shot on the next shot.

- **Excitement is normal.** Everyone, including the greatest champions, become excited and nervous during competitions. Enjoy the feelings of heightened awareness that come from competition. Keep your mind focused on following your shot plan for each shot. Being excited can actually help you do even better if you learn to **control** your excitement.
- **Use your time wisely.** It is a good idea to keep a watch or timer in view so you can pace yourself and make sure you do not run out of time. One of the most common mistakes of beginner shooters, is shooting too fast. Take advantage of the time available to you. Take a little extra time to do your pre-shot checks before each shot.
- **Take the rifle down if something is not right.** If you are not holding steady or are likely to fire a poor shot, stop trying to fire that shot, take the rifle down, rest briefly, and try again. There is plenty of time available to make sure you fire the best shots you can.

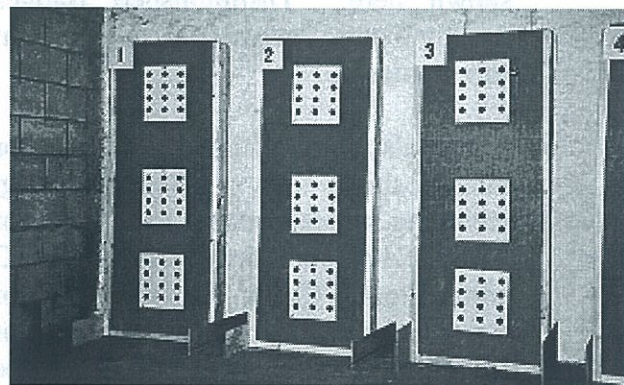

*Ten-bull targets in place for firing a 3x10 competition event.*

- **Keep yourself under control.** One of the most important lessons to learn in target shooting is the importance of **self-control**. It is natural and good to want to do well when you are in a competition. It is also tempting to become upset when there are distractions or when you fire bad shots or disappointing scores. This happens to all shooters at some point. If something goes wrong for you, take control of yourself, be determined not to let anything bother you and remind yourself that the best thing you can do is use your shot plan to focus on firing your next shot correctly.
- **Enjoy the competition experience.** **Competitions** are fun. Enjoy the experience of trying to do your best while dealing with the challenges of competition. You should always know that when you finish a competition and can say you worked hard to follow your plan and tried to do your best on each shot, that the competition was a success for you. The score you fired or where you finished in the competition is not important then. What is important, is trying hard to do your best. If you can say you did that, the competition was a success for you.

## CONCLUSION

This Student Text has introduced you to the sport of target rifle shooting. The safety skills you learned will be invaluable to you, regardless of whether you continue to participate in the sport. If learning about rifle marksmanship sparked a new interest for you in the sport of target shooting, it may have opened the doors for you to the excitement and special experiences of high school and collegiate rifle

competitions and the possibility of enjoying a great sport for a lifetime.

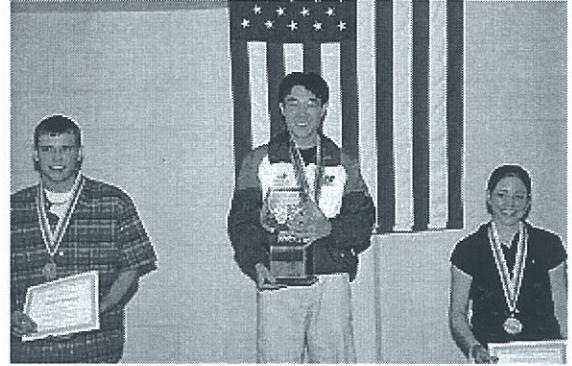

*Competition can be the ultimate test of your rifle marksmanship skills. Trying to win awards in major competitions as these award winners in the 2001 National Junior Olympic Championship have done, can become an especially challenging goal for high school rifle shooters.*



*If you can finish a competition knowing you did your best to follow your shot plan and keep yourself under control on each shot, you can be happy with your effort. The competition experience is enjoyable, whether or not you win.*



## Junior Shooter Safety Examination

### Air Rifle Safety and Range Operations

No.	Multiple Choice Questions	Answer (circle)
1	When I pick up or receive an air rifle from someone else, the <u>first</u> thing I must do is:	<ul style="list-style-type: none"> <li>a. Engage the safety</li> <li>b. Release the trigger</li> <li>c. Open the action/bolt</li> <li>d. Control the muzzle (point it in a safe direction)</li> </ul>
2	Which of these air rifle parts is not directly associated with safe gun handling?	<ul style="list-style-type: none"> <li>a. Muzzle</li> <li>b. Sights</li> <li>c. Trigger</li> <li>d. Action</li> </ul>
3	The command LOAD means:	<ul style="list-style-type: none"> <li>a. I can load my air rifle and start shooting</li> <li>b. It may occasionally be violated if accidents do not occur</li> <li>c. I can charge (pump or cock) my air rifle and load a pellet in it</li> <li>d. I can start getting ready to shoot</li> </ul>
4	Air rifle target shooting is an exceptionally safe sport because:	<ul style="list-style-type: none"> <li>a. Air rifles are not very powerful or dangerous</li> <li>b. Strict safety rules are taught and enforced</li> <li>c. Air rifle participants have been very lucky</li> <li>d. Everyone knows how to be safe with guns</li> </ul>
5	When my air rifle malfunctions (fails to fire), I must:	<ul style="list-style-type: none"> <li>a. Keep the muzzle pointed downrange</li> <li>b. Raise my hand so the Range Officer can see it</li> <li>c. Wait for instructions from the Range Officer</li> <li>d. All of the above</li> </ul>
6	Before anyone can go downrange to change targets or for any other purpose:	<ul style="list-style-type: none"> <li>a. Everyone must open their rifle actions and point their rifle muzzles up</li> <li>b. No one can go downrange until guns are placed in safe storage</li> <li>c. All air rifles must be unloaded, grounded with CBIs inserted and checked</li> <li>d. All firers must finish firing</li> </ul>
7	If I still have a loaded rifle (pellet in barrel) after the Range Officer gives the command STOP, I must:	<ul style="list-style-type: none"> <li>a. Keep my air rifle muzzle pointed downrange</li> <li>b. Raise my hand so the Range Officer can see it and announce "Loaded Rifle"</li> <li>c. Follow the Range Officer's instructions</li> <li>d. All of the above</li> </ul>
8	After I pick up or receive a gun and have made sure the muzzle is pointing in a safe direction, the <u>second</u> thing that I must do to make sure it is safe is:	<ul style="list-style-type: none"> <li>a. Open the action/bolt</li> <li>b. Dry fire the gun to see if it works</li> <li>c. Give the gun to an adult</li> <li>d. Take it to the range</li> </ul>
9	The command STOP means:	<ul style="list-style-type: none"> <li>a. Complete the shot I am attempting to fire</li> <li>b. Quickly complete the shot I am attempting to fire</li> <li>c. Immediately stop attempting to fire any more shots</li> <li>d. Tell the Range Officer I am not done</li> </ul>
10	The safest and correct way to load a pneumatic air rifle is:	<ul style="list-style-type: none"> <li>a. Open and close the charging lever, then open the action to insert a pellet</li> <li>b. Put a pellet in the barrel, then open and close the charging lever</li> <li>c. Put a pellet on the loading port, but do not close the bolt/ action until opening and closing the charging lever</li> <li>d. Open the bolt, open and close the charging lever, insert the pellet and close the bolt/action</li> </ul>
11	The most important component part of rifle safety is:	<ul style="list-style-type: none"> <li>a. The trigger</li> <li>b. The action</li> <li>c. The muzzle</li> <li>d. The person holding the rifle</li> </ul>
12	If I am with someone else who is handling a gun behind the firing line with the action closed, I should:	<ul style="list-style-type: none"> <li>a. Wait for an adult to show up</li> <li>b. Mind my own business and hope nothing bad happens</li> <li>c. Tell that person not to point the gun at me</li> <li>d. Ask that person to open the action of the gun immediately</li> </ul>

No.	Multiple Choice Questions	Answer (circle)
13	When a rifle is grounded, it must:	<ul style="list-style-type: none"> <li>a. Be fired</li> <li>b. Be lying on the floor or mat with its action open and a CBI inserted</li> <li>c. Be lying on the floor or shooting mat</li> <li>d. Be prepared for use in the next position</li> </ul>
14	When a firing line is "clear," firers may:	<ul style="list-style-type: none"> <li>a. Go down range if instructed to do so by the Range Officer</li> <li>b. Handle their rifles as long as the muzzles are pointed in a safe direction</li> <li>c. Pick up their rifles</li> <li>d. Eat lunch</li> </ul>
15	The proper time to place the index finger on the trigger is:	<ul style="list-style-type: none"> <li>a. After starting to aim at the target.</li> <li>b. After loading the rifle</li> <li>c. When the rifle is in position on the shoulder</li> <li>d. When it is time to pull the trigger</li> </ul>
16	An air rifle is considered "unloaded" if:	<ul style="list-style-type: none"> <li>a. Its action is open</li> <li>b. The firer is done shooting</li> <li>c. The action is open, there is no pellet in the barrel and a CBI is inserted</li> <li>d. The muzzle is pointed in a safe direction</li> </ul>
17	The ultimate goal or objective of gun safety training is:	<ul style="list-style-type: none"> <li>a. To reduce the number of gun-related accidents</li> <li>b. To make sure junior shooters have a good experience on the range</li> <li>c. To make target shooting free of all gun related accidents</li> <li>d. To prepare junior shooters for marksmanship competitions</li> </ul>
18	To ensure safety, I must consciously check the key parts of the guns I handle in this order:	<ul style="list-style-type: none"> <li>a. Action, Muzzle, Trigger (AMT)</li> <li>b. Barrel, Bullet, Butt plate (BBB)</li> <li>c. Muzzle, Action Trigger (MAT)</li> <li>d. Trigger, Action, Bolt (TAB)</li> </ul>
19	When I am handling a rifle, the third thing I must do after I have made sure the muzzle is pointing in a safe direction and the action is open is:	<ul style="list-style-type: none"> <li>a. Handle the rifle with my fingers outside of the trigger guard.</li> <li>b. Go ahead and place my index finger on the trigger because the action is open</li> <li>c. Dry fire the rifle to make sure it is not loaded</li> <li>d. Show the gun to my friends</li> </ul>
20	The only place I can close the bolt/action of my rifle to dry fire it or to load and fire it is:	<ul style="list-style-type: none"> <li>a. It's OK to dry fire anywhere the gun is pointing in a safe direction</li> <li>b. Any time I am forward of the Ready Line</li> <li>c. On a safe firing range</li> <li>d. On my designated firing point after the Range Officer gives instructors to do so</li> </ul>

No.	True-False Questions	Answer (circle)
1	The "Rules for Safe Gun Handling" apply only to air rifle shooting and not to other types of guns.	T or F
2	When a gun's safety is engaged, it is not necessary to open the bolt/action when carrying the rifle on a range.	T or F
3	On target ranges, the safest direction to point a gun muzzle is downrange or up towards the ceiling.	T or F
4	When I take my gun out of the gun case, it does not matter which direction I point the muzzle	T or F
5	After the Range Officer gives the command to LOAD and START, it is OK to place my index finger inside the trigger guard.	T or F
6	Even if one safe gun handling rule will make me safe, I must still follow all three gun handling rules.	T or F
7	An air rifle cannot be accidentally fired if the bolt/action remains open.	T or F
8	If I still have a pellet in the barrel of my air rifle when I finish firing, I don't need to say anything to the Range Officer, because the action on my rifle is open so the rifle cannot be accidentally fired.	T or F



No.	True-False Questions	Answer (circle)
9	No one is authorized to fire a shot until the command START is given, even if the command LOAD has already been given.	T or F
10	It's OK to shoot at my neighbor's target if I have finished firing on my target.	T or F
11	When a firer completes a firing exercise, that person is responsible for opening the rifle's action and inserting a CBI.	T or F
12	I must not bring food onto the range even if it is consumed behind the firing line.	T or F
13	All parts of my shooting position and rifle, including the muzzle of the rifle, must be behind the firing line during firing.	T or F
14	It is OK for me to go downrange to change targets if all rifles are grounded, with CBIs inserted, and checked, and the Range Officer gives instructions to go downrange.	T or F
15	I may shoot into a pellet discharge container (PDC) after the command STOP is given, if the Range Officer instructs me to do so.	T or F
16	People in the Ready Area (behind the Ready Line) may move up to the firing line during firing as long as they do not disturb the shooters.	T or F
17	Air or CO <sub>2</sub> cylinders on air rifles (CO <sub>2</sub> or compressed air) should be tightened as tightly as possible with a wrench to prevent gas leakage.	T or F
18	All personnel who handle air rifle pellets should wash their hands immediately after they leave the range.	T or F
19	Safety rules are not as important in being safe with air guns because air rifles are not very powerful.	T or F
20	A firing line is considered "Hot" when the temperature is above 20° C.	T or F
21	A firing line is considered "Clear" when all rifles are grounded, with CBIs inserted, and a Range Officer has checked the line.	T or F
22	After I finish firing, I may put my rifle down without opening the action first because it has just been fired.	T or F
23	When I open a gun case, the first thing I must do is open the gun action/bolt and insert a CBI.	T or F
24	Once an air rifle is unloaded and checked by a Range Officer, it is OK to point it in any direction.	T or F
25	I may act as an "Emergency Safety Officer" if I see someone handling an air rifle in an unsafe manner.	T or F

## Appendix A



## Individual Junior Shooter Safety Pledge

**This individual shooter Safety Pledge should be reviewed and affirmed by every junior shooter who uses an air rifle in youth marksmanship programs.**

Key Words	Personal Actions
1. Obeying commands and instructions	A Range Officer will be in charge of all range firing activities. I will listen to and immediately obey all commands and instructions given by the Range Officer.
2. Muzzle	Whenever I handle an air rifle, or guns of any kind, I will always maintain control of the muzzle so that it points in a safe direction. I will take special care to be sure I never point any gun muzzle at another person or myself.
3. Action	Whenever I handle an air rifle, or guns of any kind, I will immediately open the gun action (bolt or operating mechanism), or visually check to be sure the action is open. I will close a gun action only when I am on the firing line of a range and am authorized to do so by the Range Officer or instructor.
4. Trigger	Whenever I handle guns, I will do so without placing my finger on the trigger. I will place my finger on the trigger only when I am on the firing line, after I have placed my air rifle in a firing position and have begun to aim at the target.
5. Range Commands	I understand what the range commands <b>LOAD, START, STOP</b> and <b>UNLOAD</b> mean. I will respond to those commands whenever they are given.
6. Safe Loading	I will close the action of my air rifle or charge and load my air rifle only when I am on a designated firing point and have been given instruction or command to do so. When I charge and load my air rifle I will take special care to keep the muzzle pointed upward or downrange towards the targets.
7. Target	When I am firing on a range, I will fire only at my designated targets. I will not fire at anyone else's targets or at any other objects on the range.
8. Malfunction	If, when I am on the firing line attempting to load or fire my air rifle, my air rifle fails to fire or malfunctions, I will keep the muzzle pointed downrange and raise my hand so the Range Officer can see it. I will wait for the Range Officer to give me instructions or clear the malfunction.
9. Firing Completed	Whenever I have fired my last shot in a firing exercise, I will immediately open the action of my air rifle, ground the rifle and insert a CBI so the Range Officer can check it.
10. Loaded Air Rifle	If I still have a loaded air rifle after the command <b>STOP</b> is given, or even if I think there may still be a pellet or gas charge in my rifle, I will keep the muzzle pointed downrange, raise my hand so the Range Officer can see it and announce " <b>Loaded Rifle.</b> " I will wait for the Range Officer to give instruction for unloading the rifle.
11. Going Downrange	I understand that whenever anyone must go downrange to hang targets or for any other reason, that my air rifle action must be opened, my rifle must be grounded with a CBI inserted and I may not handle my air rifle while anyone is forward of the firing line.
12. Hygiene	I will protect my health by never bringing food or open drink containers on the range. I will always wash my hands immediately after I finish firing on the range.
13. Emergency Safety Officer	I am also responsible for making sure everyone around me handles guns safely. If I observe someone pointing a gun muzzle at another person, handling a gun with a closed action or handling a gun with their finger on the trigger, I will immediately instruct or assist that person to safely control the muzzle, open the action or place the finger in a safe position.

